

HY-BRID LIFTS™

BY CUSTOM EQUIPMENT LLC

PARTS MANUAL

SELF-PROPELLED AERIAL WORK PLATFORM

SUPO-686

REV A



HB-830

HB-830CE

HB-1230

HB-1230CE

SERIES II

Model HB-830 Serial #Ranges:
D03-20000-D03-20003

Model HB-830CE Serial #Ranges:
E03-20000-29999

Model HB-1230 Serial #Ranges:
D08-20001-D08-20043
D08-20046-D08-20063

Model HB-1230CE Serial #Ranges:
E08-25001-25999

TABLE OF CONTENTS

NOTES.....	2
SERIAL NUMBER REFERENCE	3
TABLE OF CONTENTS	4
INDEX OF FIGURES.....	5
SECTION 1 BASE	6
1.1 POTHOLE GUARD PARTS	6
1.2 CASTER PARTS	7
1.3 CASTER SUBPARTS	8
1.4 REAR WHEEL SUBPARTS.....	9
1.5 DRIVE PARTS.....	10
1.6 DRIVE SUBPARTS.....	11
1.7 BRAKE SUBPARTS	11
1.8 PUMP PARTS - ANSI/CSA	12
1.9 PUMP PARTS - CE	13
1.10 PUMP SUBPARTS - ANSI/CSA	14
1.11 PUMP SUBPARTS - CE	15
1.12 MISCELLANEOUS BASE PARTS	16
SECTION 2 CONTROLS	18
2.1 ELECTRICAL PARTS - ANSI.....	18
2.2 ELECTRICAL PARTS - CE.....	20
2.3 UPPER CONTROL PARTS - ANSI	22
2.4 UPPER CONTROL PARTS - CE	23
2.5 LOWER CONTROL PARTS - ANSI	24
2.6 LOWER CONTROL PARTS - CE.....	25
2.7 MAIN CABLE SUBPARTS	26
2.8 SELECTOR SWITCH SUBPARTS	27
2.9 E-STOP SWITCH SUBPARTS.....	27
2.10 MASTER POWER SWITCH SUBPARTS	28
2.11 KEY SWITCH SUBPARTS.....	28
SECTION 3 SCISSORS	30
3.1 SCISSORS PARTS - HB-830.....	30
3.2 SCISSORS PARTS - HB-1230	32
3.3 CYLINDER SUBPARTS - ANSI	34
3.4 CYLINDER SUBPARTS - CE	35
SECTION 4 PLATFORM & RAILS.....	36
SECTION 5 DECALS.....	38
5.1 DECALS - HB-1230 - ANSI.....	38
5.2 DECALS - HB-1230 - CE	40
5.3 DECALS - HB-830 - ANSI.....	42
5.4 DECALS - HB-830 - CE.....	44
SECTION 6 OPTIONS & MISCELLANEOUS	46

INDEX OF FIGURES

FIGURE 1: Pothole Guard Parts.....	6
FIGURE 2: Caster Parts.....	7
FIGURE 3: Caster Subparts	8
FIGURE 4: Rear Wheel Subparts.....	9
FIGURE 5: Drive Parts.....	10
FIGURE 6: Drive Subparts.....	11
FIGURE 7: Brake Subparts	11
FIGURE 8: Pump Parts - ANSI/CSA.....	12
FIGURE 9: Pump Parts - CE.....	13
FIGURE 10: Pump Subparts - ANSI/CSA.....	14
FIGURE 11: Pump Subparts - CE.....	15
FIGURE 12: Misc Base Parts.....	16
FIGURE 13: Electrical Parts - ANSI.....	18
FIGURE 14: Electrical Parts - CE	20
FIGURE 15: Upper Control Parts - ANSI.....	22
FIGURE 16: Upper Control Parts - CE	23
FIGURE 17: Lower Control Parts - ANSI.....	24
FIGURE 18: Lower Control Parts - CE.....	25
FIGURE 19: Main Cable Subparts	26
FIGURE 20: Selector Switch Subparts.....	27
FIGURE 21: E-Stop Switch Subparts	27
FIGURE 22: Master Power Switch Subparts	28
FIGURE 23: Key Switch Subparts.....	28
FIGURE 24: Scissors Parts - HB-830.....	30
FIGURE 25: Scissors Parts - HB-1230	32
FIGURE 26: Cylinder Subparts - ANSI.....	34
FIGURE 27: Cylinder Subparts - CE.....	35
FIGURE 28: Platform & Rails.....	36
FIGURE 29: Decals - HB-1230 - ANSI.....	38
FIGURE 30: Decals - HB-1230 - CE	40
FIGURE 31: Decals - HB-830 - ANSI.....	42
FIGURE 32: Decals - HB-830 - CE	44
FIGURE 33: Options & Miscellaneous.....	46

1.1 | POTHOLE GUARD PARTS

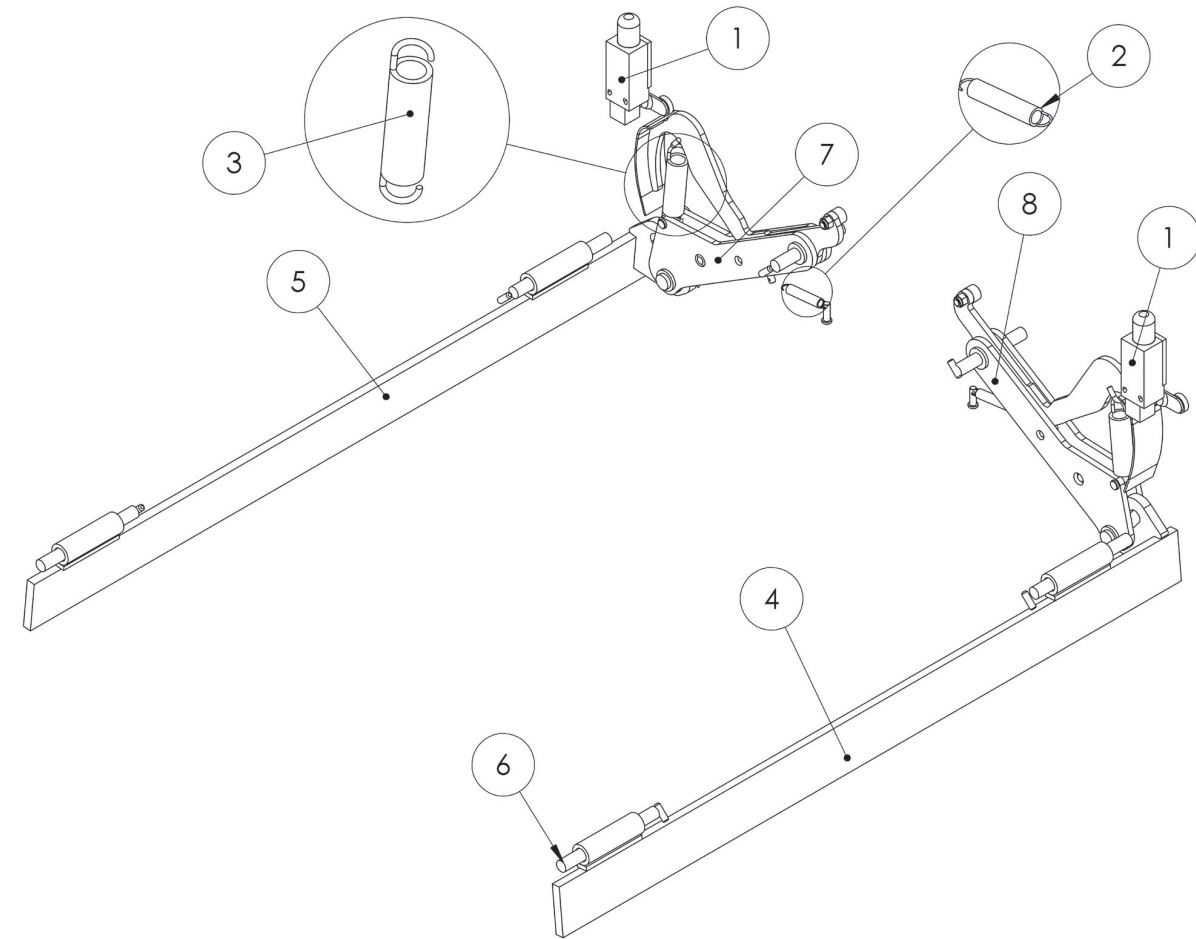

FIGURE 1: Pothole Guard Parts

Item #	Part Number	Part Description	Notes	Qty	Superseded By
1	ELEC-123-5	SWITCH,LIMIT,ROT LVR,NO/NC PO		2	
2	HARD-696	SPRING,EXT 2.25 X 0.38		2	
3	HARD-804	SPRING, EXT 4.0 X .81		2	
4	129-01-254-01	BASE,PH BAR L (HBMD)		1	
5	129-01-255-01	BASE,PH BAR R (HBMD)		1	
6	RND-HB-002-P	PIN,HINGE,0.50,5.0		4	
7	129-21-202-14-K	ASM,BASE PH ARM R		1	129-21-263-14-K
7	129-21-263-14-K	ASM,BASE PH ARM R		1	
8	129-21-202-09-K	ASM,BASE PH ARM L		1	
8	129-21-263-09-K	ASM,BASE PH ARM L		1	129-21-263-09-K

1.2 | CASTER PARTS

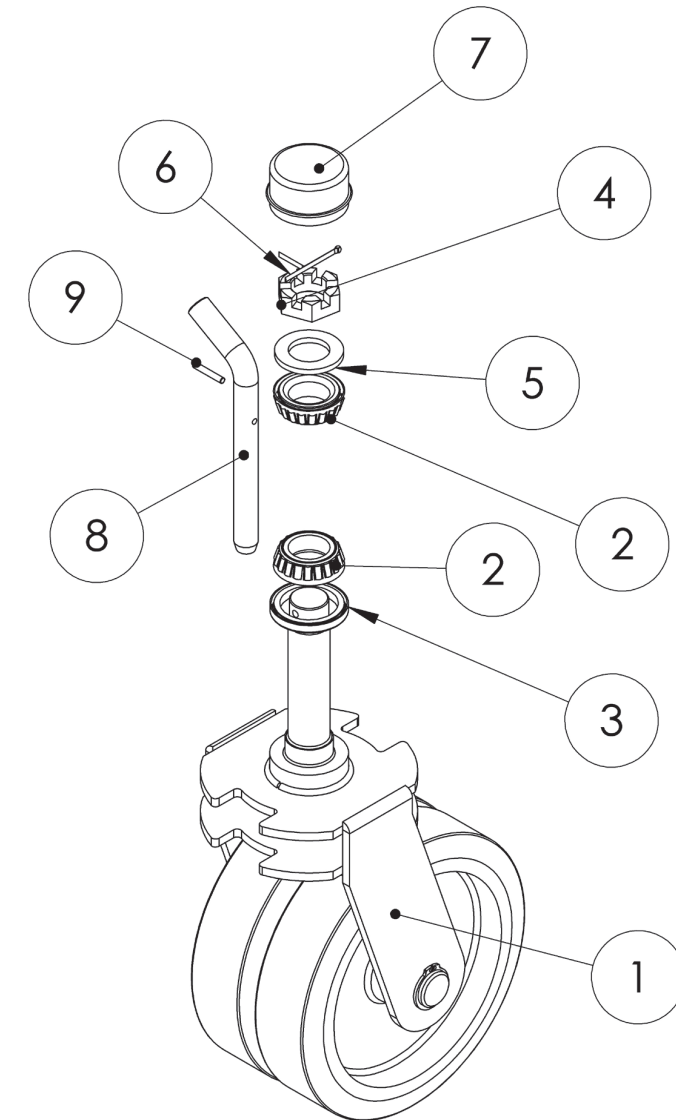

FIGURE 2: Caster Parts

Item #	Part Number	Part Description	Notes	Qty	Superseded By
1	129-21-215-50-K	ASM,CASTER		1	
2	WHEE-718	BEARING		2	
3	WHEE-717	SEAL		1	
4	WHEE-719	1-14 HEX SLOTTED AXLE NUT		1	
5	WHEE-716	WASHER,1.06IDx1.75ODx.155THK		1	
6	HARD-725	COTTER PIN, 3/16 X 2		1	
7	WHEE-714-100	HUB,COVER		1	
8	129-01-101-05	HITCH PIN,5/8 X 5		2	
9	129-01-102-03	COILED SPRING PIN, 5/32,1 L		2	

1.3 | CASTER SUBPARTS

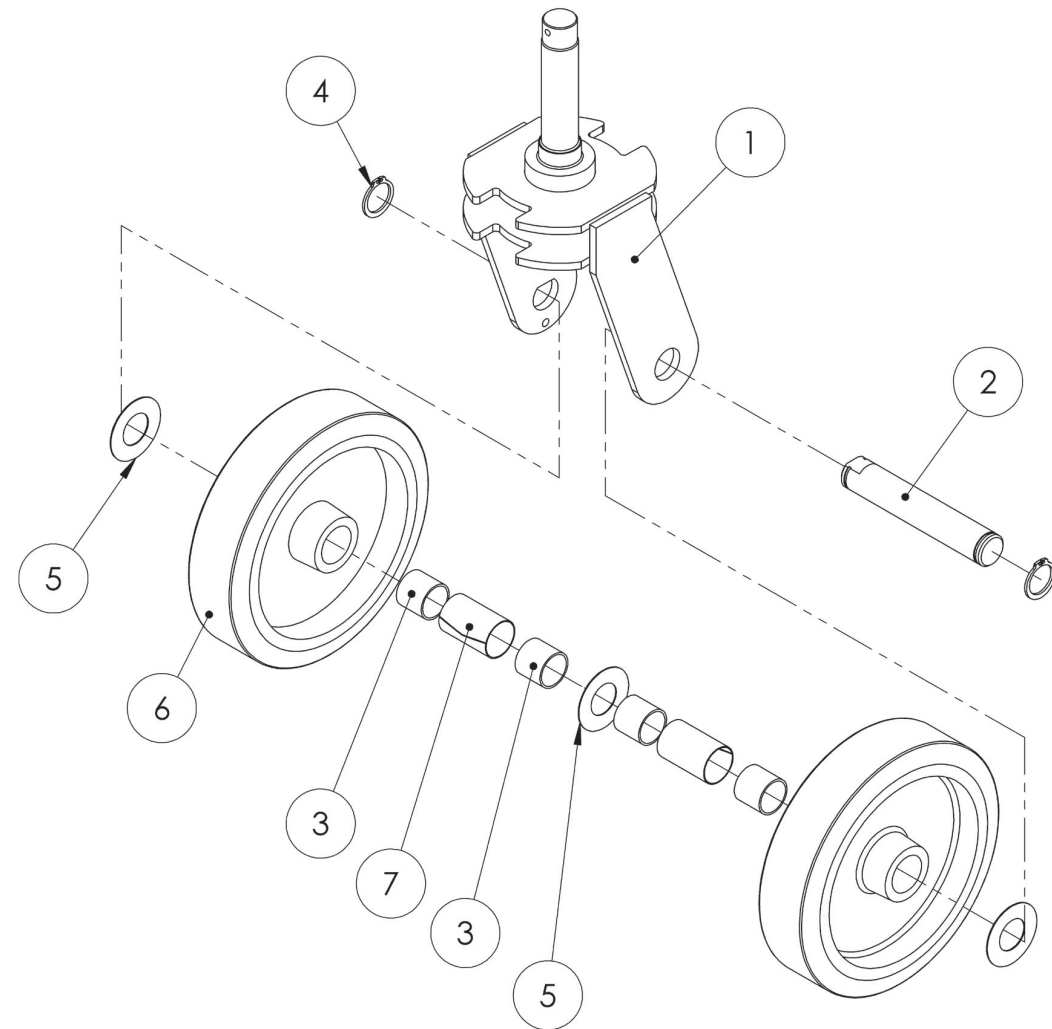

FIGURE 3: Caster Subparts

Item #	Part Number	Part Description	Notes	Qty	Superseded By
1	129-01-260-01	BASE,CASTER WLDMNT		1	
2	129-06-023-02	BASE,CASTER PIN		1	
3	HARD-001-2	DU BEARING,1.0 ID X 1.0 L		4	
4	HARD-021	RET RING 1.0		2	
5	WHEE-609-SS	WASHER, 1.015ID,2OD,.03 THK SS		3	
6	WHEE-706-KIT	WHL,8X2,GREY NM RUBBER		2	
7	WHEE-708	WHL, RACEWAY SPLIT 2.0		2	

1.4 | REAR WHEEL SUBPARTS

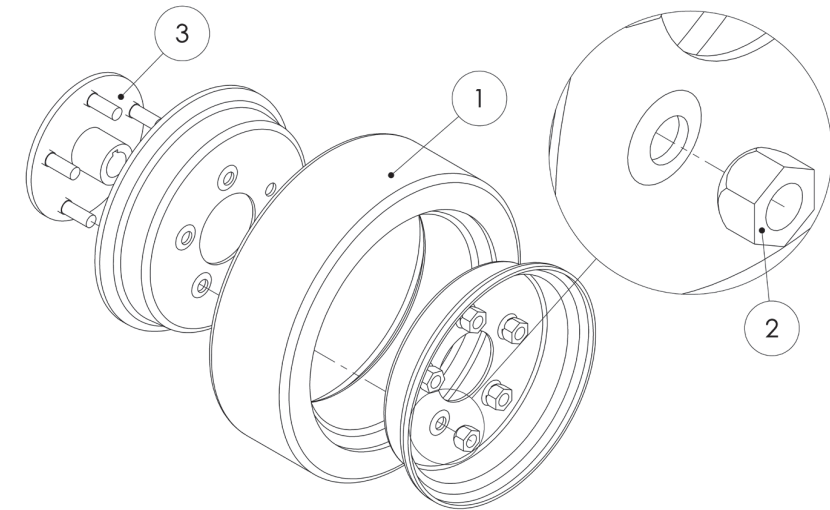

FIGURE 4: Rear Wheel Subparts

Item #	Part Number	Part Description	Notes	Qty	Superseded By
1	WHEE-617	WHL,12X4,NM RUBBER		1	
2	WHEE-721	WHL,LUG NUT 1/2-20		5	
3	WHEE-730-02	HUB,KEYWAY 1.0,2.0		1	

1.5 | DRIVE PARTS

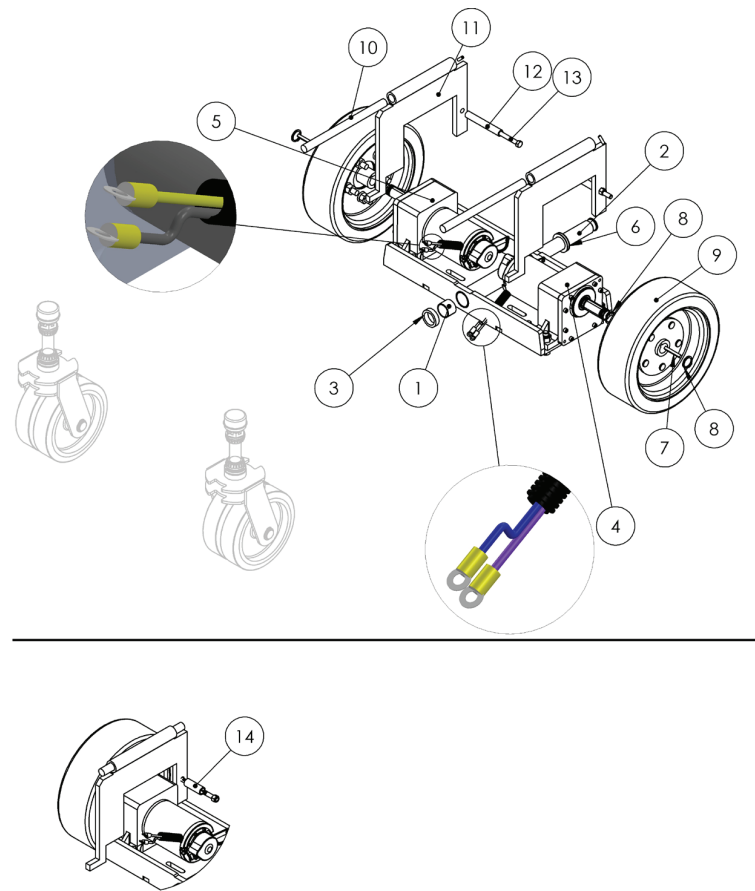

FIGURE 5: Drive Parts

Item #	Part Number	Part Description	Notes	Qty	Superseded By
1	129-01-211-02	BASE,REAR PIVOT WLDMNT		1	
2	129-06-202-02	PIN,DRIVE MNT,1.25,14.06		1	
3	129-01-243-04	BASE,SPACER PIVOT		1	
4	ELEC-626-5B-KIT	R-WITH LEADS	BLUE/VIOLET LEADS	1	
4	ELEC-626-5R-KIT	R-WITH LEADS	Superseded; BLUE/VIOLET LEADS	0	ELEC-626-5B-KIT
5	ELEC-626-5A-KIT	DRIVE MOTOR,24VELE,HB DUM	GREY/YEL LEADS	1	
5	ELEC-626-5L-KIT	DRIVE MOTOR,24VELE,HB DUM	Superseded; GREY/YEL LEADS	0	ELEC-626-5A-KIT
6	WASH-1026	1.25X1.87X0.05 WASH		2	
7	HARD-157	0.25X0.25x2.00 KEY		2	
8	HARD-021	1.00 RETAINING RING,EXT		4	
9	WHEE-618-KIT	WHL,12X4 NM RUBBER W/HUB		2	
10	129-01-265-02	PIN,HINGE,0.75		2	
11	129-01-292-02	BASE,DRIVE LOCK WLDMNT		2	
12	129-01-307-02	SPACER,LOCK PLATE		2	
13	BOLT-3813	3/8-16 X 6.00 HHCS		2	
14	HARD-702	SPRING,EXT 3X.75,OD	REPLACE WITH 129-01-307-02 & BOLT-3813	0	

1.6 | DRIVE SUBPARTS

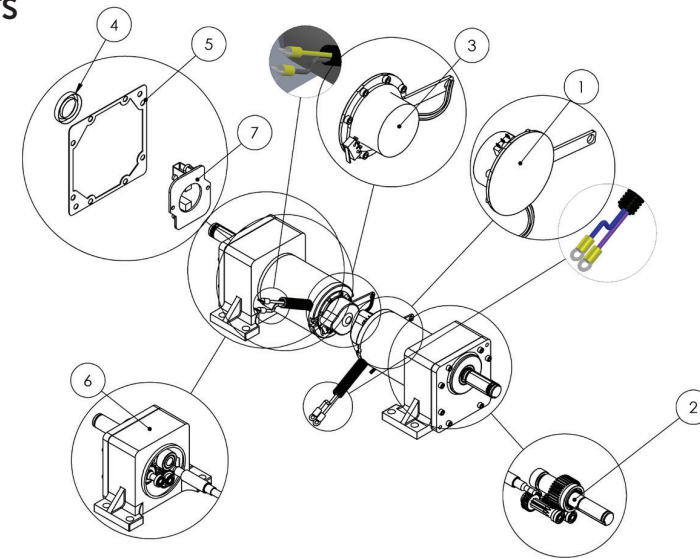

FIGURE 6: Drive Subparts

Item #	Part Number	Part Description	Notes	Qty	Superseded By
1	ELEC-627-5R	DRIVE MOTOR,BRAKE	DUMORE: HOUSING ALL SILVER, LEFT BRAKE ON HB-1230	1	
2	ELEC-626-4G	DRIVE MOTOR GEARS,HB,DUM		1	
3	ELEC-627-5L	DRIVE MOTOR,BRAKE	DUMORE: HOUSING ALL SILVER, RIGHT BRAKE ON HB-1230	1	
4	ELEC-626-4A	DRIVE MOTOR SHAFT SEAL,DUM		1	
5	ELEC-626-4B	DRIVE MOTOR HOUSING GASKET,DUM		1	
6	ELEC-626-4C	DRIVE MOTOR GEARBOX,DUM		1	
7	ELEC-626-4BRUSH	BRUSH KIT,DUMORE		1	

1.7 | BRAKE SUBPARTS

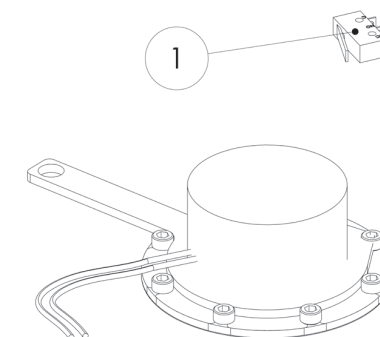

FIGURE 7: Brake Subparts

Item #	Part Number	Part Description	Notes	Qty	Superseded By
1	ELEC-126-7-KIT	SWITCH,LIMIT,STRAIGHT LVR MICR	DUMORE: HOUSING ALL SILVER	1	

1.8 | PUMP PARTS - ANSI/CSA ANSI/CSA

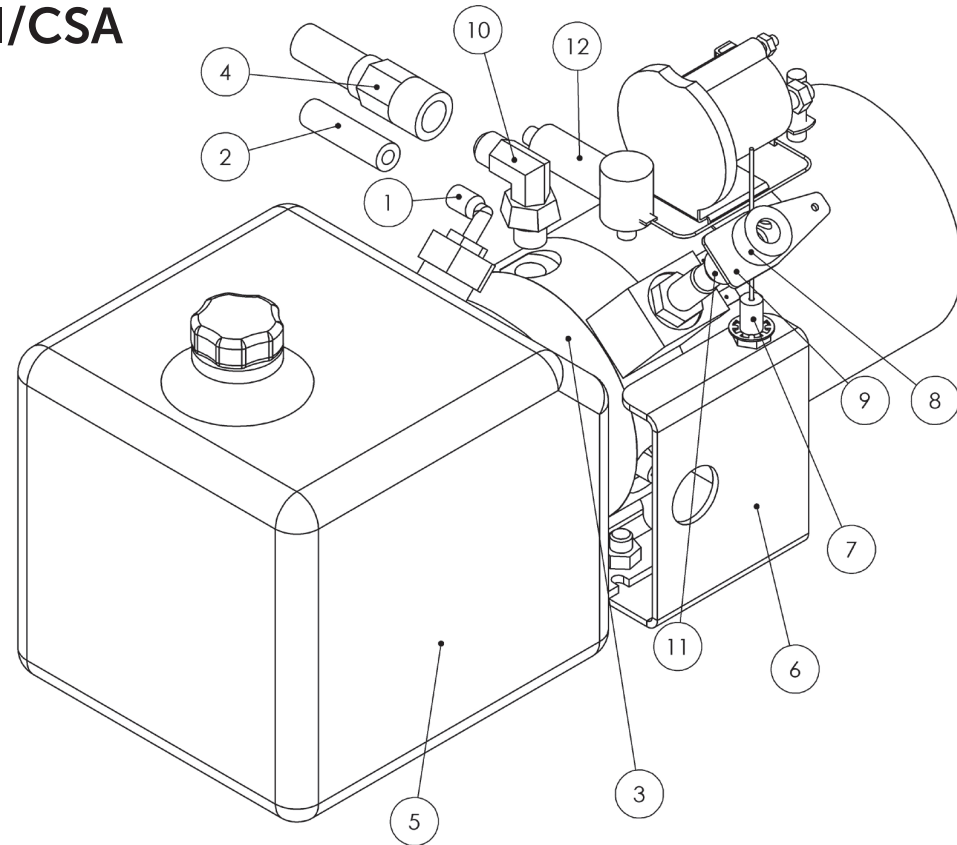

FIGURE 8: Pump Parts - ANSI/CSA

Item #	Part Number	Part Description	Notes	Qty	Superseded By
1	HYDR-019	FITTING,ELB,NPTM 3/8-1/4 PUSH		1	
2	HYDR-022-3	LOW PRESSURE HOSE	Quantity in inches (102 FOR 830, 132 for 1230)	102 132	
3	HYDR-050-9	PUMP,24VDC,0.125,0.88,1.75		1	
4	HYDR-600	HOSE ASM,HB-2X		1	
5	HYDR-032	HYDRAULIC OIL	Not available as a replacement part. Replace with Flomite #150, Dexron II, Mobil-DTE 2 or equivalent 32 weight implement oil.	0	
6	129-01-104-01	BASE,E-DOWN BRKT		1	
7	HARD-644-04	LOW FRICTION CABLE, 43/52		1	
8	HARD-650	0.44X0.88X0.44 SHAFT COLLAR		1	
9	LAS-M115	SCISSOR,PLATE E-DOWN ACT		1	
10	HYDR-677	FITNG,ELB,JICM 9/16-SAEORM #6		1	
11	HARD-621	038X0.63X075 SLEEVE BEARING		1	
12	ELEC-634D	TERMINAL BOOT (BLACK)		1	

1.9 | PUMP PARTS - CE CE

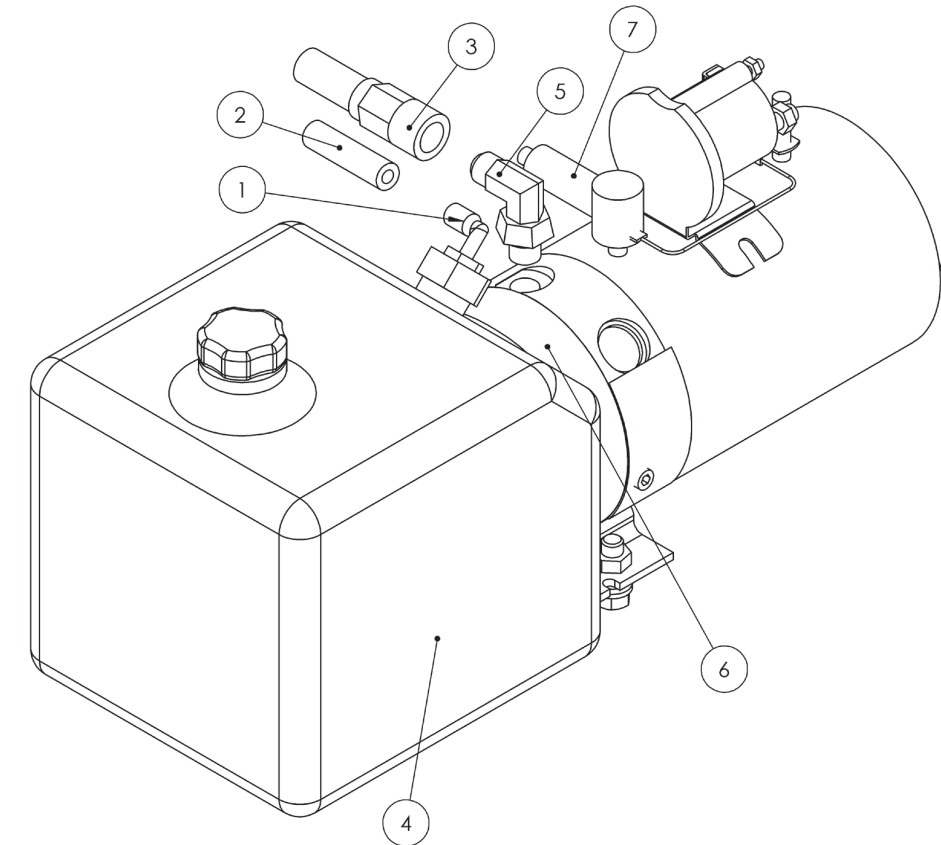

FIGURE 9: Pump Parts - CE

Item #	Part Number	Part Description	Notes	Qty	Superseded By
1	HYDR-019	FITTING,ELB,NPTM 3/8-1/4 PUSH		1	
2	HYDR-022-3	LOW PRESSURE HOSE	Quantity in inches (102 FOR 830, 132 for 1230)	102 132	
3	HYDR-050-9	PUMP,24VDC,0.125,0.88,1.75		1	
4	HYDR-600	HOSE ASM,HB-2X		1	
5	HYDR-032	HYDRAULIC OIL	Not available as a replacement part. Replace with Flomite #150, Dexron II, Mobil-DTE 2 or equivalent 32 weight implement oil.	0	
6	129-01-104-01	BASE,E-DOWN BRKT		1	
7	HARD-644-06	LOW FRICTION CABLE,86/96		1	
8	HARD-650	0.44X0.88X0.44 SHAFT COLLAR		1	
9	LAS-M115	SCISSOR,PLATE E-DOWN ACT		1	
10	HYDR-677	FITNG,ELB,JICM 9/16-SAEORM #6		1	
11	HARD-621	038X0.63X075 SLEEVE BEARING		1	
12	ELEC-634D	TERMINAL BOOT (BLACK)		1	

1.10 | PUMP SUBPARTS - ANSI/CSA
ANSI/CSA

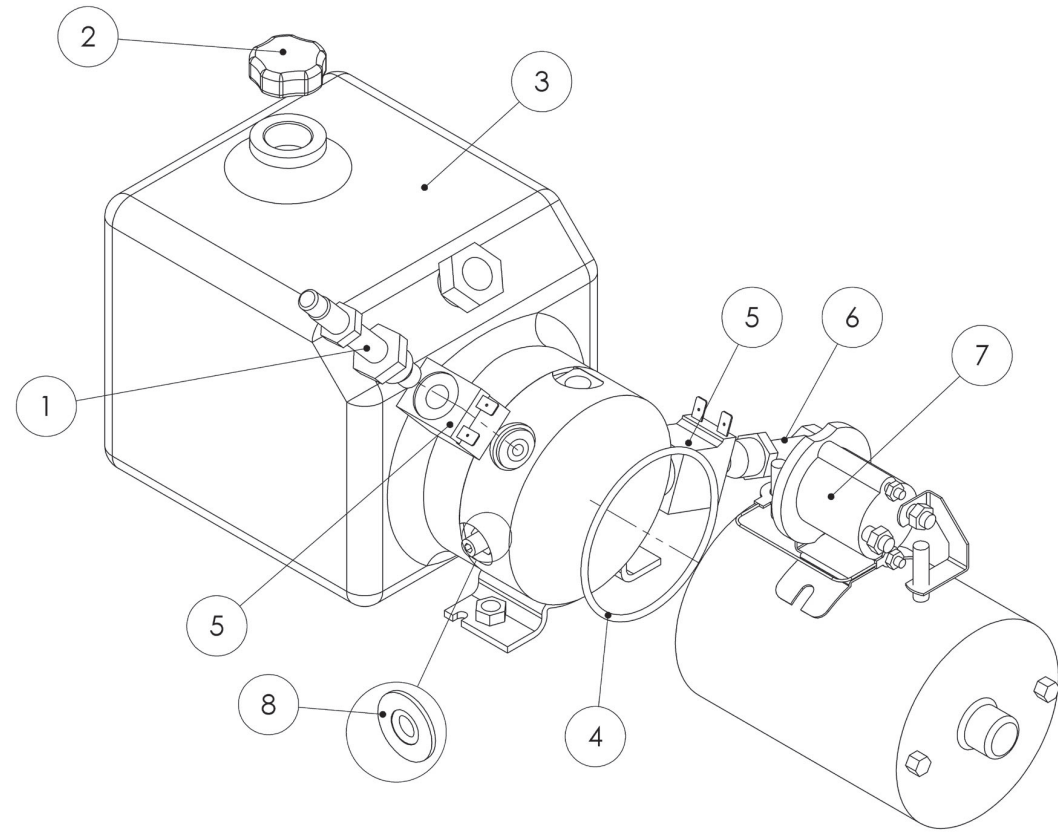

FIGURE 10: Pump Subparts - ANSI/CSA

Item #	Part Number	Part Description	Notes	Qty	Superseded By
1	HYDR-007-2E-5	VALVE,NC,2W/2P,#8,DWN,PULL,DEL		1	
2	HYDR-042	PUMP RESERVOIR CAP		1	
3	HYDR-067-3	PUMP RESERVOIR,0.88 GAL		1	
4	HYDR-068	PUMP RESERVOIR O-RING		1	
5	HYDR-664	COIL,18V		2	
6	HYDR-665	VALVE,NO,2W/2P,#8,UP		1	
7	HYDR-666-1	SOLENOID,24V,ISOLATED,SPST		1	
8	HYDR-667	WASH,0.38 ID,0.75 OD,PRES SEAL		1	

1.11 | PUMP SUBPARTS - CE
CE

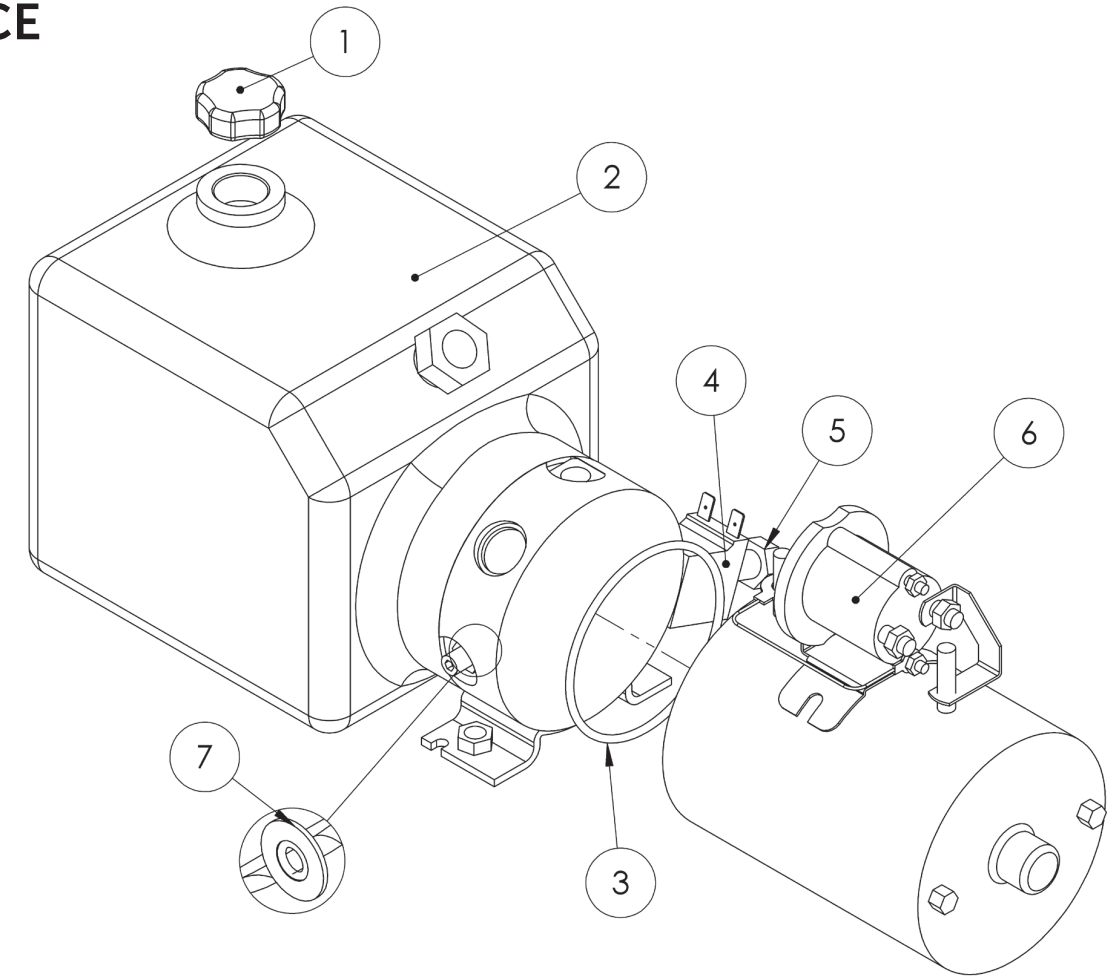

FIGURE 11: Pump Subparts - CE

Item #	Part Number	Part Description	Notes	Qty	Superseded By
1	HYDR-042	PUMP RESERVOIR CAP		1	
2	HYDR-067-3	PUMP RESERVOIR,0.88 GAL		1	
3	HYDR-068	PUMP RESERVOIR O-RING		1	
4	HYDR-664	COIL,18V		1	
5	HYDR-665	VALVE,NO,2W/2P,#8,UP		1	
6	HYDR-666-1	SOLENOID,24V,ISOLATED,SPST		1	
7	HYDR-667	WASH,0.38 ID,0.75 OD,PRES SEAL		1	

1.12 | MISCELLANEOUS BASE PARTS

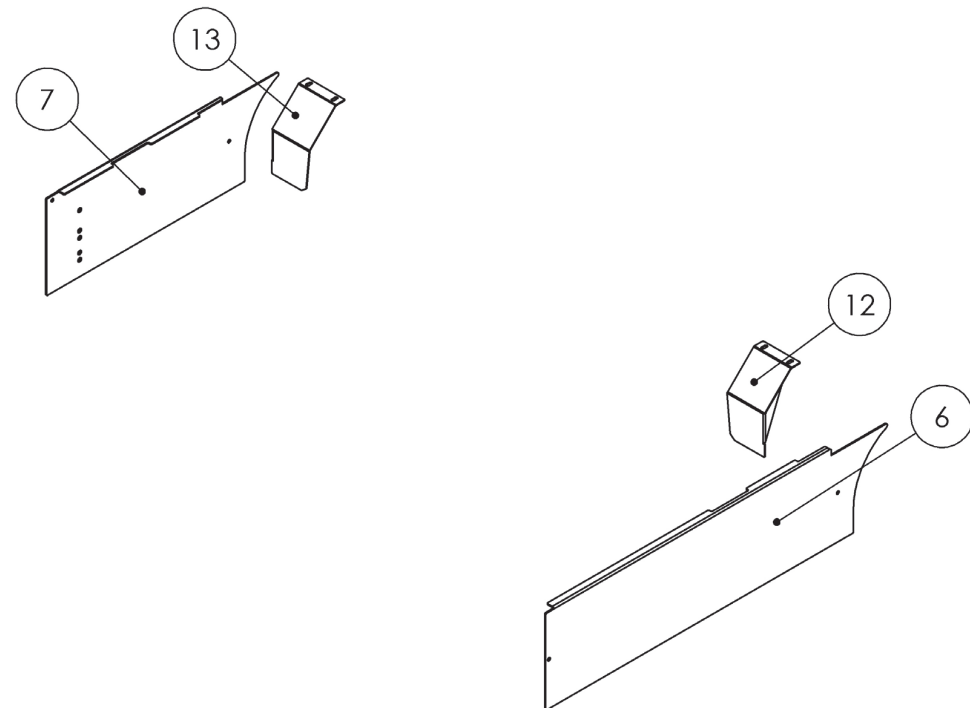
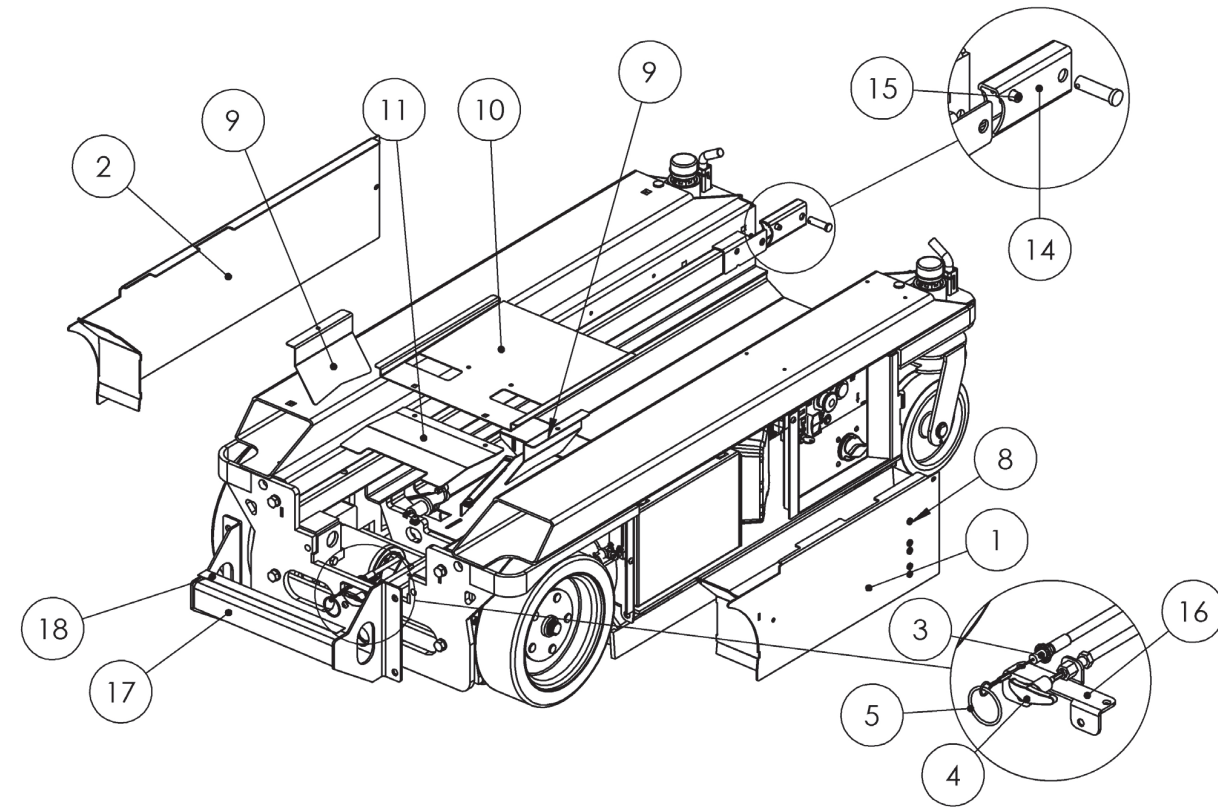
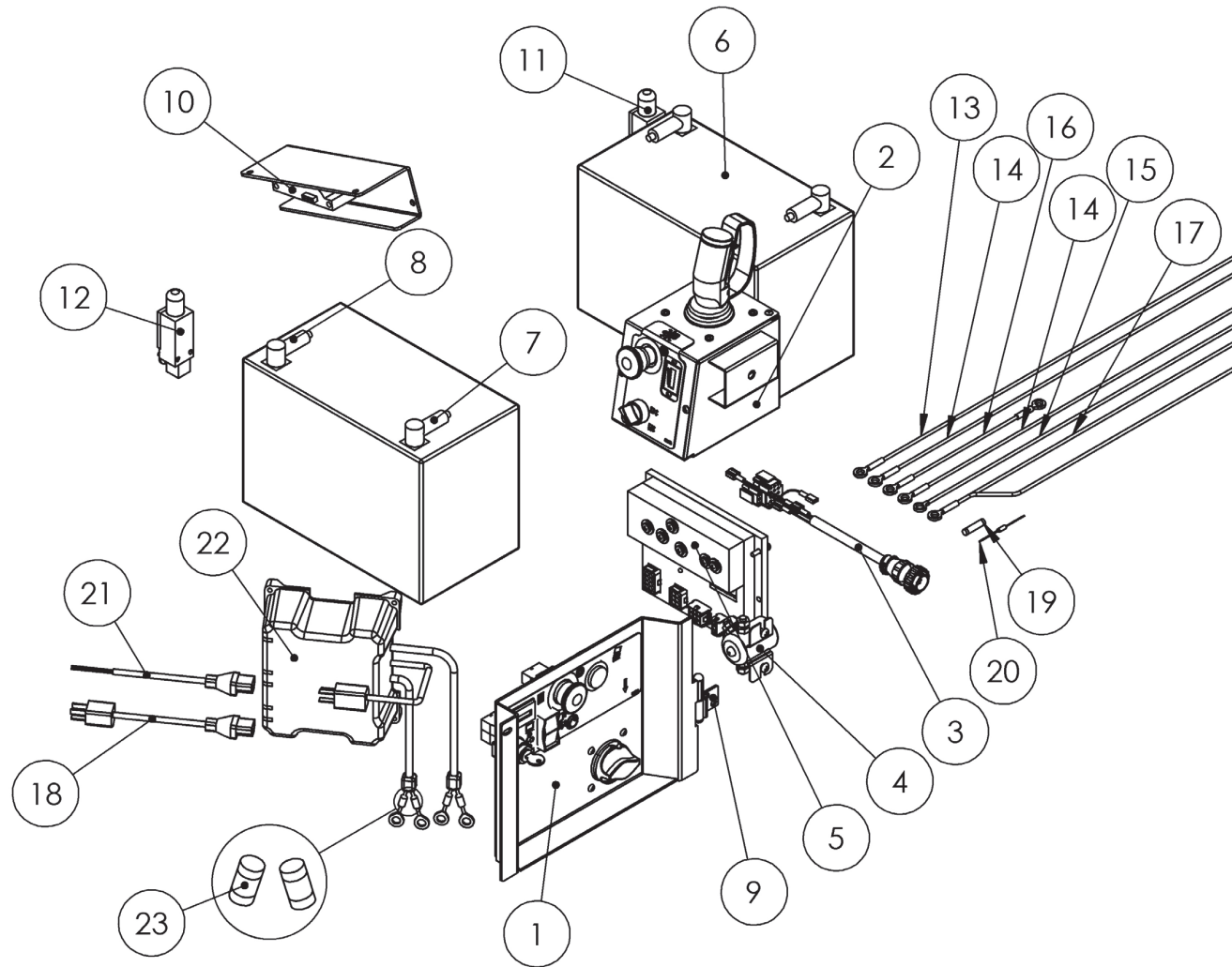

FIGURE 12: Misc Base Parts

Item #	Part Number	Part Description	Notes	Qty	Superseded By
1	129-05-210-01	BASE,COVER WLDMNT R		1	
2	129-05-211-01	BASE,COVER WLDMNT L		1	
3	HARD-644-04	LOW FRICTION CABLE, 43/52		1	
4	HARD-644-06	86/96 LOW FRICTION CABLE		1	
5	HARD-651	1.40 ID,RING		1	
6	129-05-203-01	BASE,COVER,L	Superseded;	1	129-05-211-01
7	129-05-202-01	BASE,COVER,R	Superseded;	1	129-05-210-01
8	HARD-658	PLUG,0.38 DIA,TRANSPARENT		5	
9	129-01-279-03	BASE,COVER REAR		2	
10	129-01-270-01	BASE,MOTOR COVER PLATE		1	
11	129-01-272-01	BASE,COVER REAR		1	
12	129-01-296-06	BASE,COVER LS	Superseded;	1	129-05-210-01
13	129-01-296-11	BASE,COVER LS	Superseded;	1	129-05-211-01
14	129-01-232-02	BASE,SCISSORS LOCK		2	
15	HARD-067	0.38SNAP BUTTON,SINGLE END		2	
16	129-01-268-01	BASE,E-DOWN BRKT REAR WLDMNT		1	
17	LAS-M100-E-PC	BASE,ACCESS STEP		1	
18	MISC-030-01-KIT	ANTI-SLIP TAPE,1, 13.75 LENGTH		1	

2.1 | ELECTRICAL PARTS - ANSI ANSI



Item #	Part Number	Part Description	Notes	Qty	Superseded By
1	129-21-206-50	ASM,CTL LWR (HBMD S2)	Mates with board 129-21-227, Panel has hinge	1	
2	129-21-006-50	ASM,CTL UPR		1	
2	129-21-249-50	ASM,CTL UPR	MAY BE SUBSTITUTED FOR 129-21-006-50 BUT LED WOULD NOT BE FUNCTIONAL	1	
3	129-21-007-50	CTL,WIRE HARNESS MAIN HB-1230		1	
4	HYDR-666	SOLENOID,24V,ISOLATED,SPST		1	
5	129-21-227-50	BOARD,DRIVE/LIFT CTL HB-MID		1	
6	ELEC-047-5	BATTERY,12V,GR27 AGM		2	
7	ELEC-634D	TERMINAL BOOT (BLACK)		2	
8	ELEC-634C	TERMINAL COVER (RED)		2	
9	129-01-305-01	BASE,COVER HINGE		1	
10	ELEC-647	SENSOR,ANGLE		1	
11	ELEC-123-5	SWITCH,LIMIT,ROT LVR,NO/NC PO		1	
12	ELEC-123-5	SWITCH,LIMIT,ROT LVR,NO/NC PO		1	
13	ELEC-641C	CABLE,6GA,RED,50,B/R		1	
14	ELEC-641A	CABLE,6GA,BLACK,63,B/B		2	
15	ELEC-641E	CABLE,6GA,BLACK,22.00,B/B		1	
16	129-01-090-50	CABLE,6GA,RED,10,R/R,.38 EYES		1	
17	129-01-090-51	CBL,6GA,RED,42&50,R/R,.38 EYES		1	
18	ELEC-639-3	CORD,NEMA 515/IEC C13,36		1	
19	ELEC-670-2	FUSE 20 AMP AGC		1	
20	ELEC-809-2	RESISTOR 1K OHM, 1 WATT		1	
21	ELEC-639-11	CORD,IEC AC WIRE/IEC C13,36.0		1	
22	ELEC-747	CHARGER,24V	PCS	1	
23	ELEC-670-6	FUSE 30 AMP,PCS		4	
24	WD-129-20-201-50	WD,HB-1230 S2	WIRING DIAGRAM	1	
25	WS-129-20-201-50	ELEC SCH,HB-1230 S2	ELECTRICAL SCHEMATIC	1	

FIGURE 13: Electrical Parts - ANSI

2.2 | ELECTRICAL PARTS - CE
CE

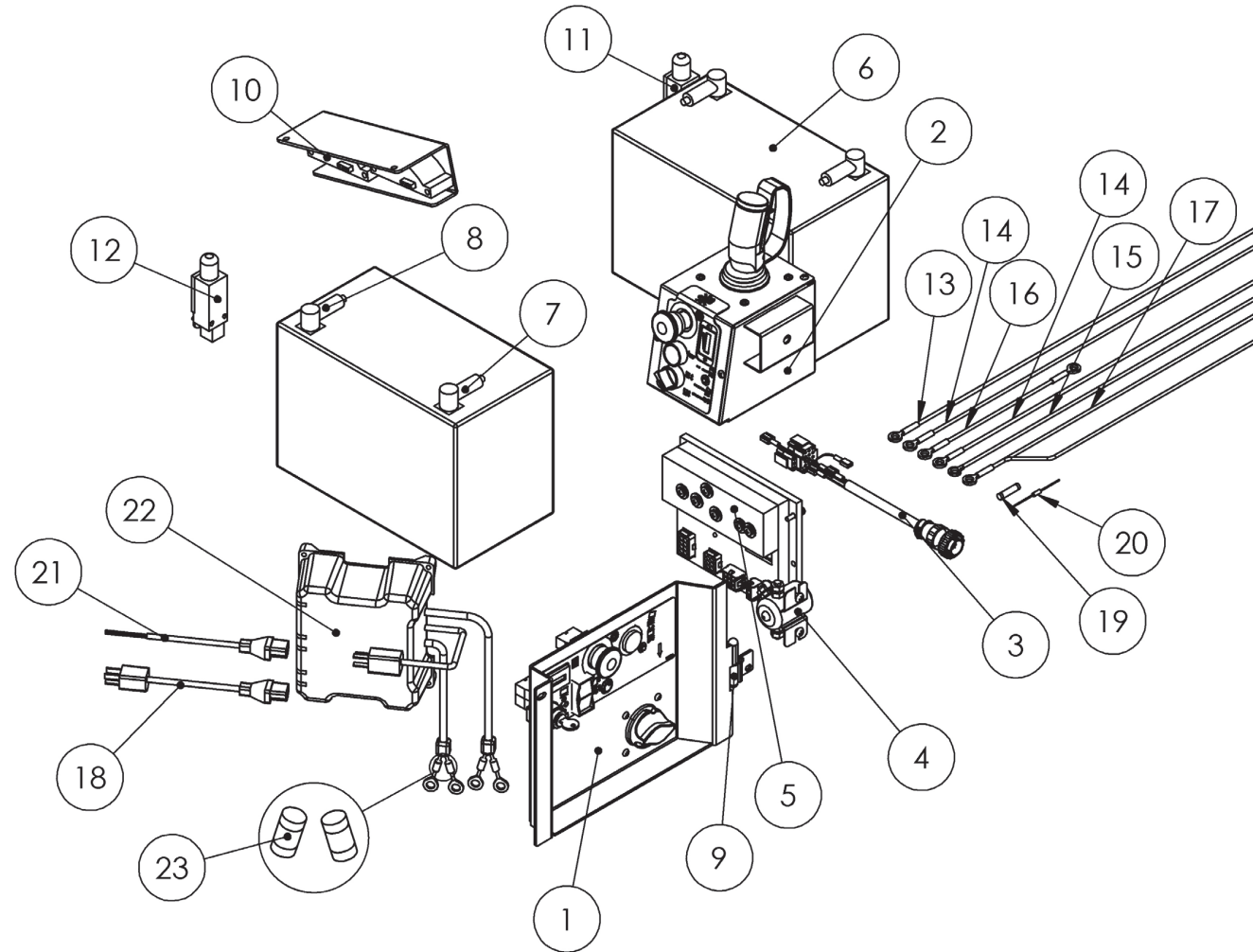

Item #	Part Number	Part Description	Notes	Qty	Superseded By
1	129-21-206-51	ASM,CTL LWR (HBMD S2)	Mates with board 129-21-227, Panel has hinge	1	
2	129-21-006-51	ASM,CTL UPR		1	
3	129-21-007-50	CTL,WIRE HARNESS MAIN HB-1230		1	
4	HYDR-666	SOLENOID,24V,ISOLATED,SPST		1	
5	129-21-227-51	BOARD,DRIVE/LIFT CTL HB-MID		1	
6	ELEC-047-5	BATTERY,12V,GR27 AGM		2	
7	ELEC-634D	TERMINAL BOOT (BLACK)		2	
8	ELEC-634C	TERMINAL COVER (RED)		2	
9	129-01-305-01	BASE,COVER HINGE		1	
10	ELEC-647	SENSOR,ANGLE		2	
11	ELEC-123-5	SWITCH,LIMIT,ROT LVR,NO/NC PO		1	
12	ELEC-123-5	SWITCH,LIMIT,ROT LVR,NO/NC PO		1	
13	ELEC-641C	CABLE,6GA,RED,50,B/R		1	
14	ELEC-641A	CABLE,6GA,BLACK,63,B/B		2	
15	ELEC-641E	CABLE,6GA,BLACK,22.00,B/B		1	
16	129-01-090-50	CABLE,6GA,RED,10,R/R,.38 EYES		1	
17	129-01-090-51	CBL,6GA,RED,42&50,R/R,.38 EYES		1	
18	ELEC-639-3	CORD,NEMA 515/IEC C13,36		1	
19	ELEC-670-2	FUSE 20 AMP AGC		1	
20	ELEC-809-2	RESISTOR 1K OHM, 1 WATT		1	
21	ELEC-639-11	CORD,IEC AC WIRE/IEC C13,36.0		1	
22	ELEC-747-KITA	CHARGER,24V	PCS	1	
23	ELEC-670-6	FUSE 30 AMP,PCS		4	
24	WD-129-20-201-51	WD,HB-1230CE S2	WIRING DIAGRAM	1	
25	WS-129-20-201-51	ELEC SCH,HB-1230CE S2	ELECTRICAL SCHEMATIC	1	

FIGURE 14: Electrical Parts - CE

2.3 | UPPER CONTROL PARTS - ANSI
ANSI

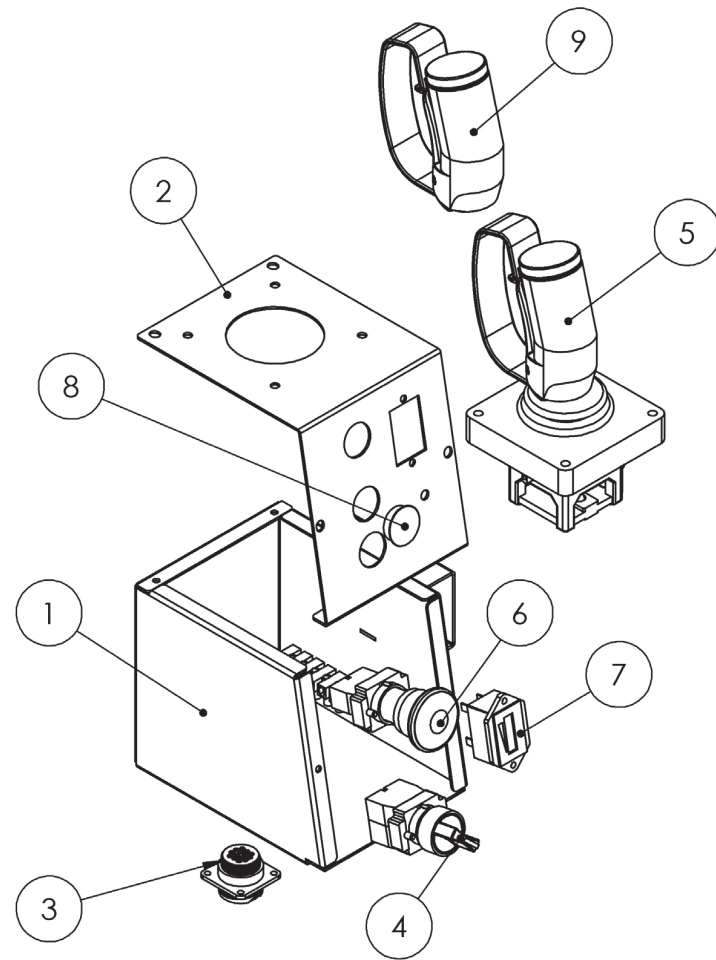

FIGURE 15: Upper Control Parts - ANSI

Item #	Part Number	Part Description	Notes	Qty	Superseded By
1	129-03-202-01	RAIL,CTL BOX		1	
2	129-03-201-01	RAIL,CTL UPR PANEL		1	
3	129-21-006-90	CTL,WIRE HARNESS,UPR CTL		1	
4	ELEC-002C-KIT	SWITCH,ROTARY MAINTAINED		1	
5	ELEC-606	JOYSTICK,MULTI-AXIS	Superseded;	1	ELEC-609
5	ELEC-609	JOYSTICK,MULTI-AXIS W/GUARD		1	
6	ELEC-071-KIT	BUTTON,PUSH/PULL RED E-STOP		1	
7	ELEC-610-4	METER,VOLT,24V		1	
8	HARD-706	PLUG,0.88 DIA,BLACK		1	
9	ELEC-609-KIT	JOYSTICK,MULTI-AXIS GUARD KIT		1	
10	WD-129-21-006-50	WD,UPR CTL HB-1230 S1	WIRING DIAGRAM	1	

2.4 | UPPER CONTROL PARTS - CE
CE

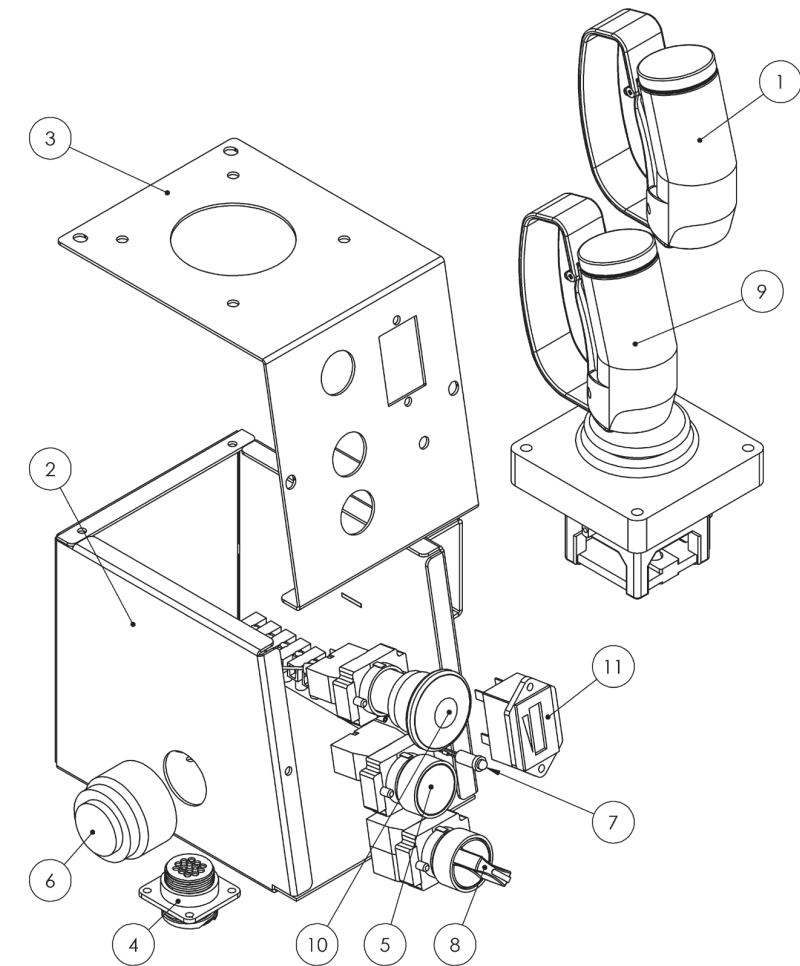

FIGURE 16: Upper Control Parts - CE

Item #	Part Number	Part Description	Notes	Qty	Superseded By
1	ELEC-609-KIT	JOYSTICK,MULTI-AXIS GUARD KIT		1	
2	129-03-202-06	RAIL,CTL BOX		1	
3	129-03-201-01	RAIL,CTL UPR PANEL		1	
4	129-21-006-90	CTL,WIRE HARNESS,UPR CTL		1	
5	ELEC-604	BUTTON,PUSH BLACK		1	
6	ELEC-635-4	ALARM, CONTINUOUS		1	
7	ELEC-636	LED, RED		1	
8	ELEC-002C-KIT	SWITCH,ROTARY MAINTAINED		1	
9	ELEC-606	JOYSTICK,MULTI-AXIS	Superseded;	1	ELEC-609
9	ELEC-609	JOYSTICK,MULTI-AXIS W/GUARD		1	
10	ELEC-071-KIT	BUTTON,PUSH/PULL RED E-STOP		1	
11	ELEC-610-4	METER,VOLT,24V		1	
12	WD-129-21-006-51	WD,UPR CTL HB-1230CE S2	WIRING DIAGRAM	1	

2.5 | LOWER CONTROL PARTS - ANSI
ANSI

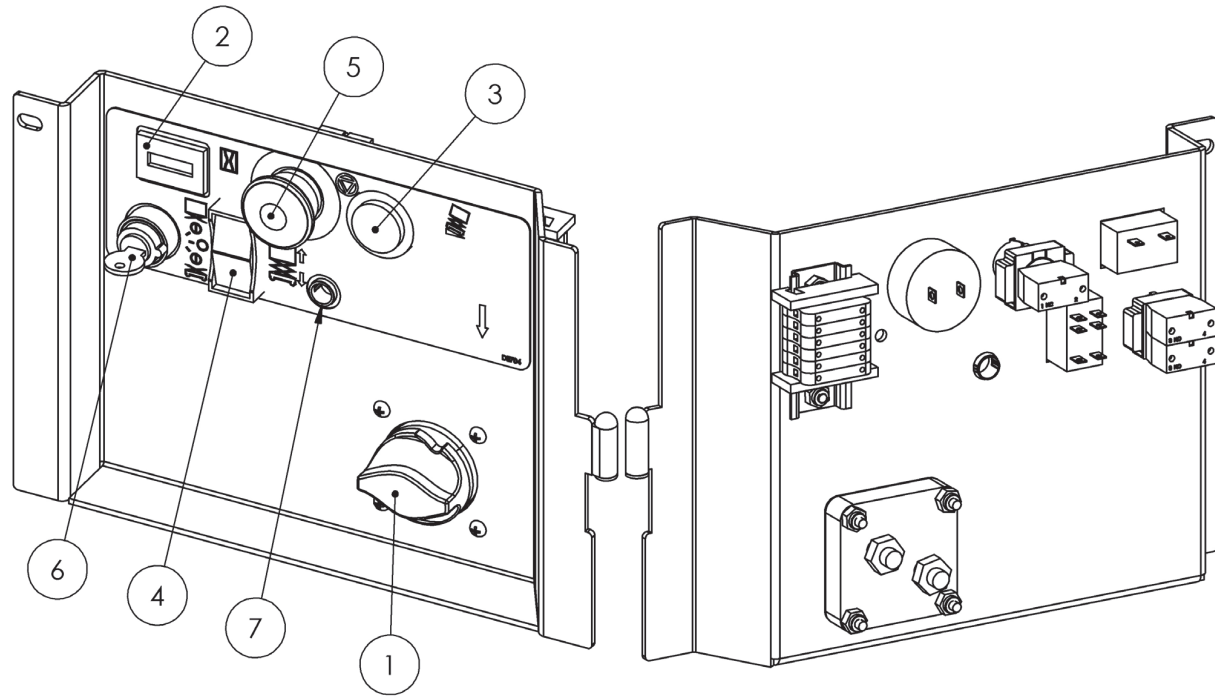

FIGURE 17: Lower Control Parts - ANSI

Item #	Part Number	Part Description	Notes	Qty	Superseded By
1	ELEC-633-4	SWITCH,MASTER DISCONNECT		1	
2	ELEC-610-2	METER,HOUR		1	
3	ELEC-635-4	ALARM, CONTINUOUS		1	
4	ELEC-133B	SWITCH,ROCKER DPDT		1	
5	ELEC-071-KIT	BUTTON,PUSH/PULL RED E-STOP		1	
6	ELEC-073D-KIT	SWITCH,KEY,3-POS MAINTAINED		1	
7	HARD-692	PLUG,0.50 DIA,TRANSPARENT		1	
8	WD-129-21-206-50	WD,LWR CTL HB-1230 S2	WIRING DIAGRAM	1	

2.6 | LOWER CONTROL PARTS - CE
CE

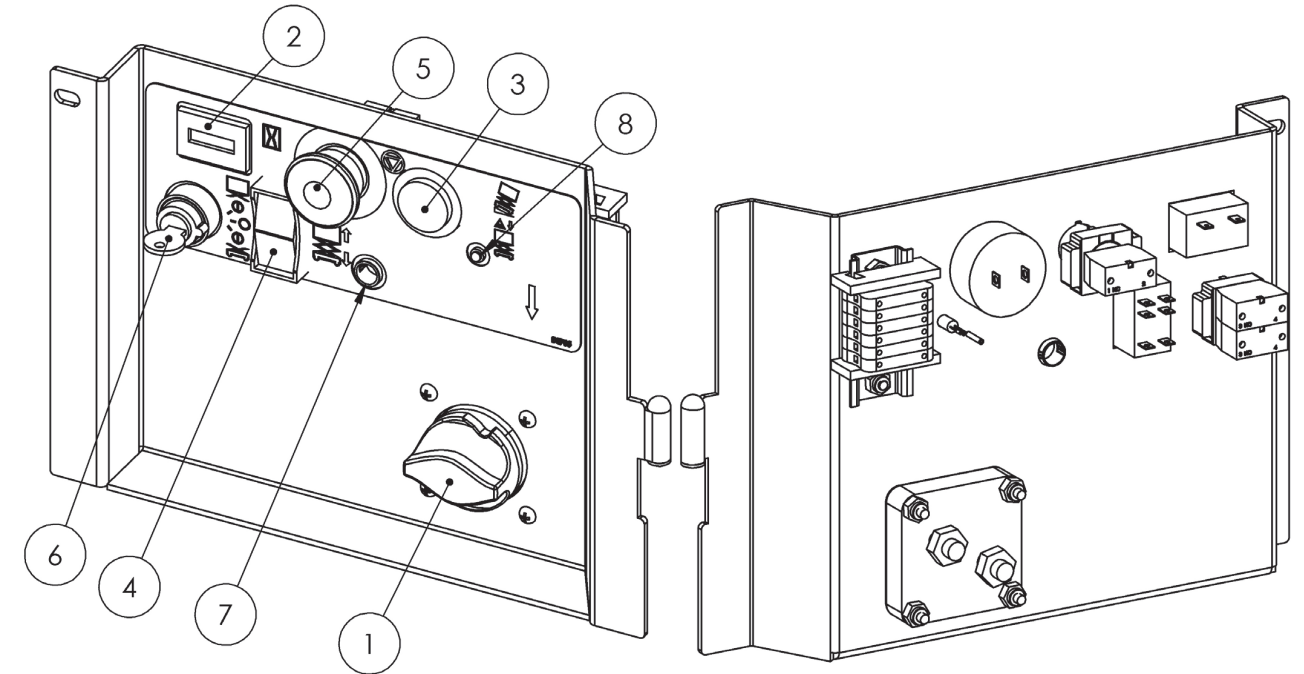

FIGURE 18: Lower Control Parts - CE

Item #	Part Number	Part Description	Notes	Qty	Superseded By
1	ELEC-633-4	SWITCH,MASTER DISCONNECT		1	
2	ELEC-610-2	METER,HOUR		1	
3	ELEC-635-4	ALARM, CONTINUOUS		1	
4	ELEC-133B	SWITCH,ROCKER DPDT		1	
5	ELEC-071-KIT	BUTTON,PUSH/PULL RED E-STOP		1	
6	ELEC-073D-KIT	SWITCH,KEY,3-POS MAINTAINED		1	
7	HARD-692	PLUG,0.50 DIA,TRANSPARENT		1	
8	ELEC-636	LED, RED		1	
9	WD-129-21-206-51	WD,LWR CTL HB-1230CE S2	WIRING DIAGRAM	1	

2.7 | MAIN CABLE SUBPARTS

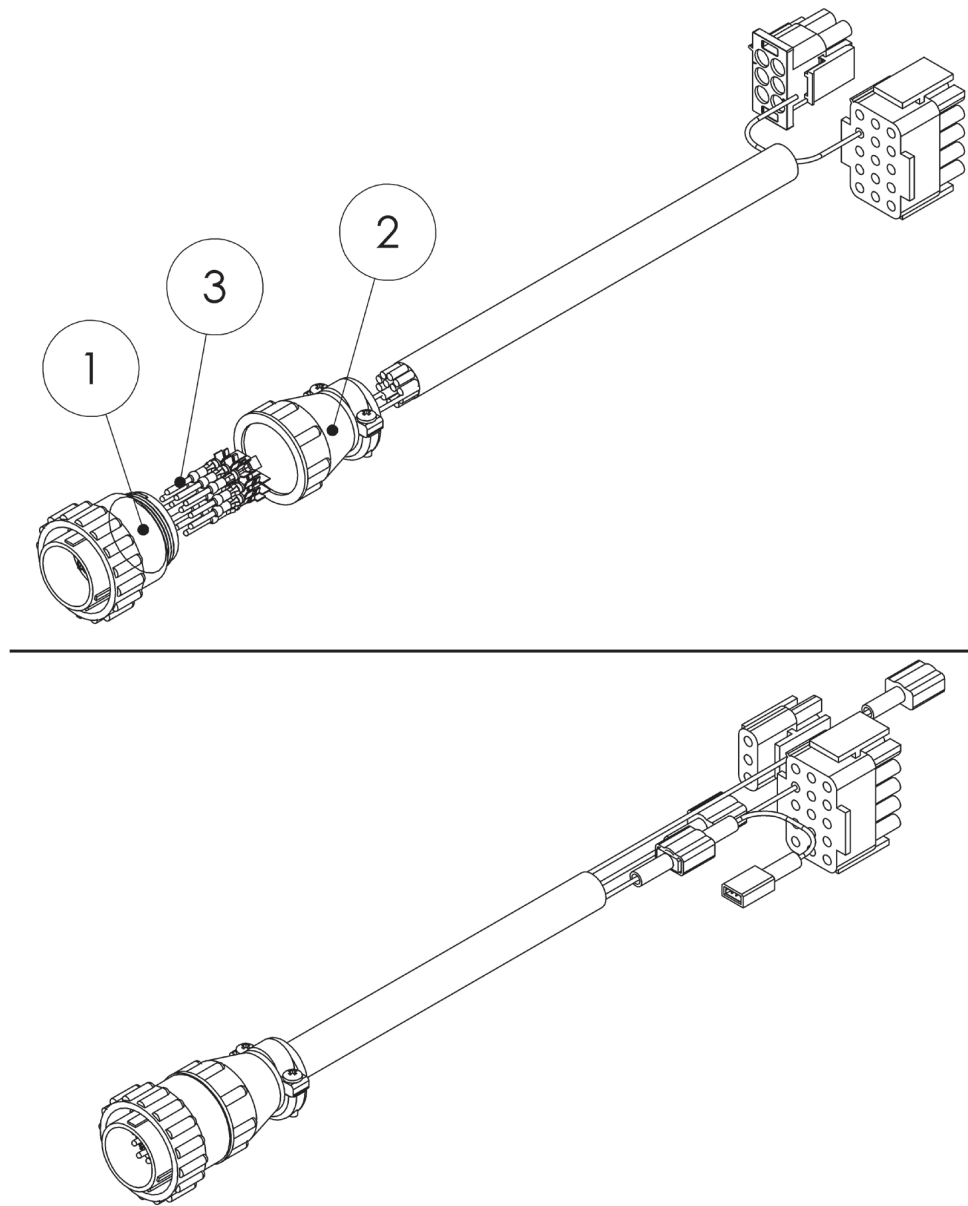

FIGURE 19: Main Cable Subparts

Item #	Part Number	Part Description	Notes	Qty	Superseded By
1	ELEC-749	CONN,CPC,PLUG,14 POS		1	
2	ELEC-750	CABLE CLAMP,CPC,BACK SHELL		1	
3	ELEC-752	CONTACT PIN,CPC,14-18GA TIN		12	

2.8 | SELECTOR SWITCH SUBPARTS

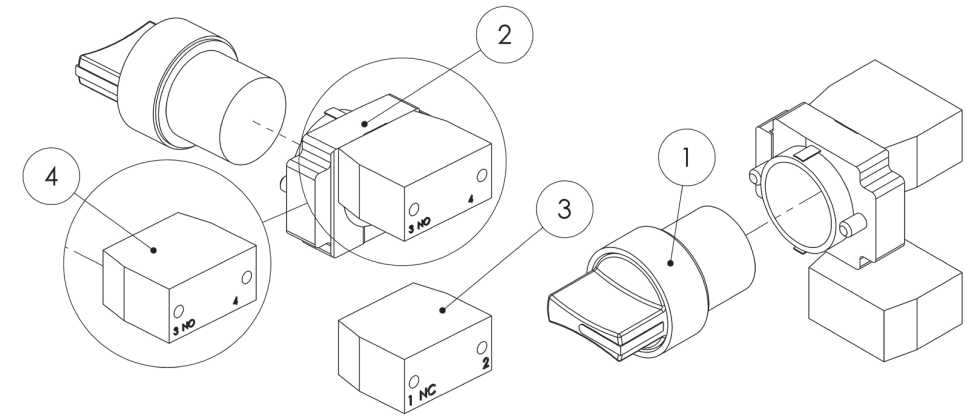

FIGURE 20: Selector Switch Subparts

Item #	Part Number	Part Description	Notes	Qty	Superseded By
1	ELEC-002C	SWITCH,ROTARY,MAINTAINED		1	
2	ELEC-871-KIT	CONTACT BLOCK,NO W/BASE		1	
3	ELEC-072	CONTACT BLOCK,NC		1	
4	ELEC-603	CONTACT BLOCK,NO		1	

2.9 | E-STOP SWITCH SUBPARTS

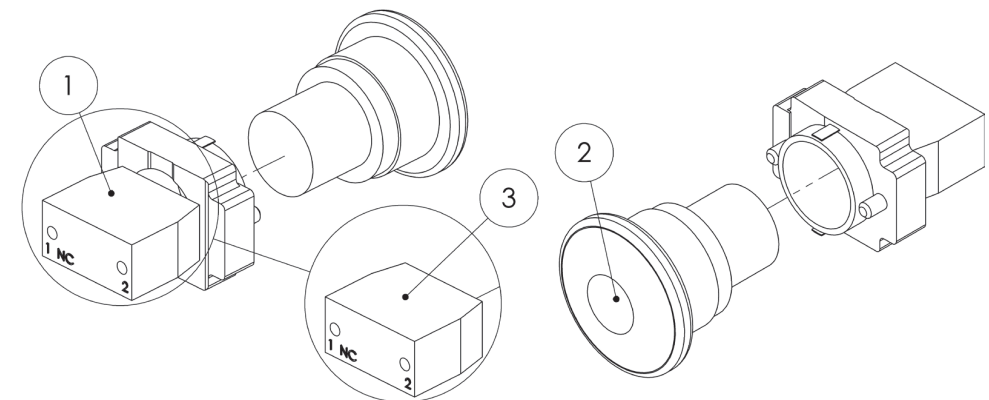

FIGURE 21: E-Stop Switch Subparts

Item #	Part Number	Part Description	Notes	Qty	Superseded By
1	ELEC-872-KIT	CONTACT BLOCK,NC W/BASE		1	
2	ELEC-071	BUTTON,PUSH/PULL RED E-STOP		1	
3	ELEC-072	CONTACT BLOCK,NC		1	

2.10 | MASTER POWER SWITCH SUBPARTS

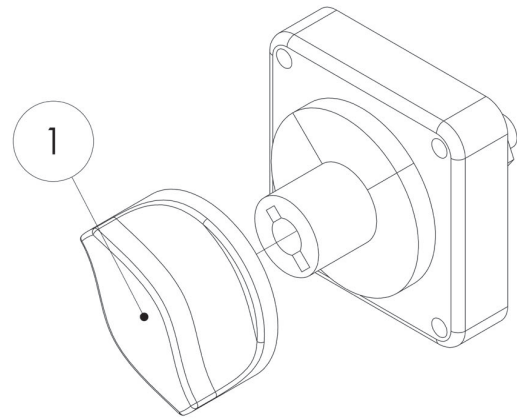

FIGURE 22: Master Power Switch Subparts

Item #	Part Number	Part Description	Notes	Qty	Superseded By
1	ELEC-633-5	SWITCH KNOB,MASTER DISCONNECT		1	

2.11 | KEY SWITCH SUBPARTS

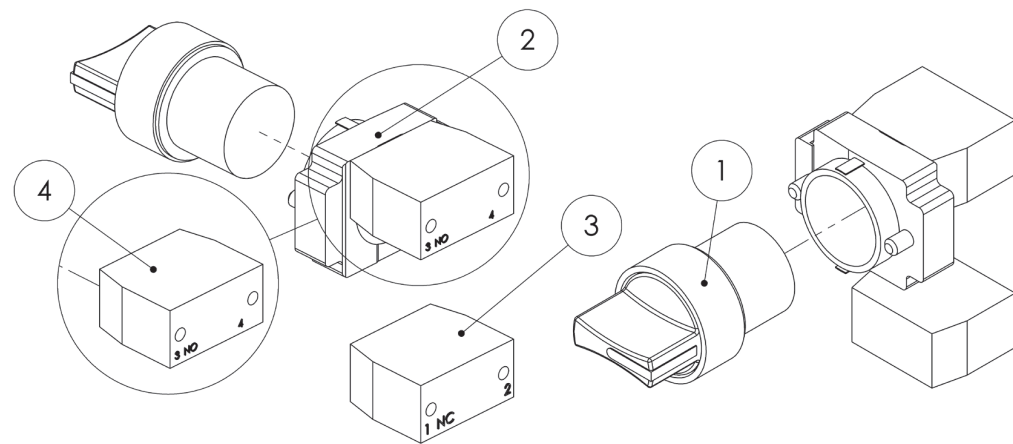

FIGURE 23: Key Switch Subparts

Item #	Part Number	Part Description	Notes	Qty	Superseded By
1	ELEC-073EKEY	KEY,SPARE		1	
2	ELEC-603	CONTACT BLOCK,NO		1	
3	ELEC-871-KIT	CONTACT BLOCK,NO W/BASE		1	
4	ELEC-073D	SWITCH,KEY,3-POS MAINTAINED		1	

THIS PAGE WAS INTENTIONALLY LEFT BLANK

3.1 | SCISSORS PARTS - HB-830

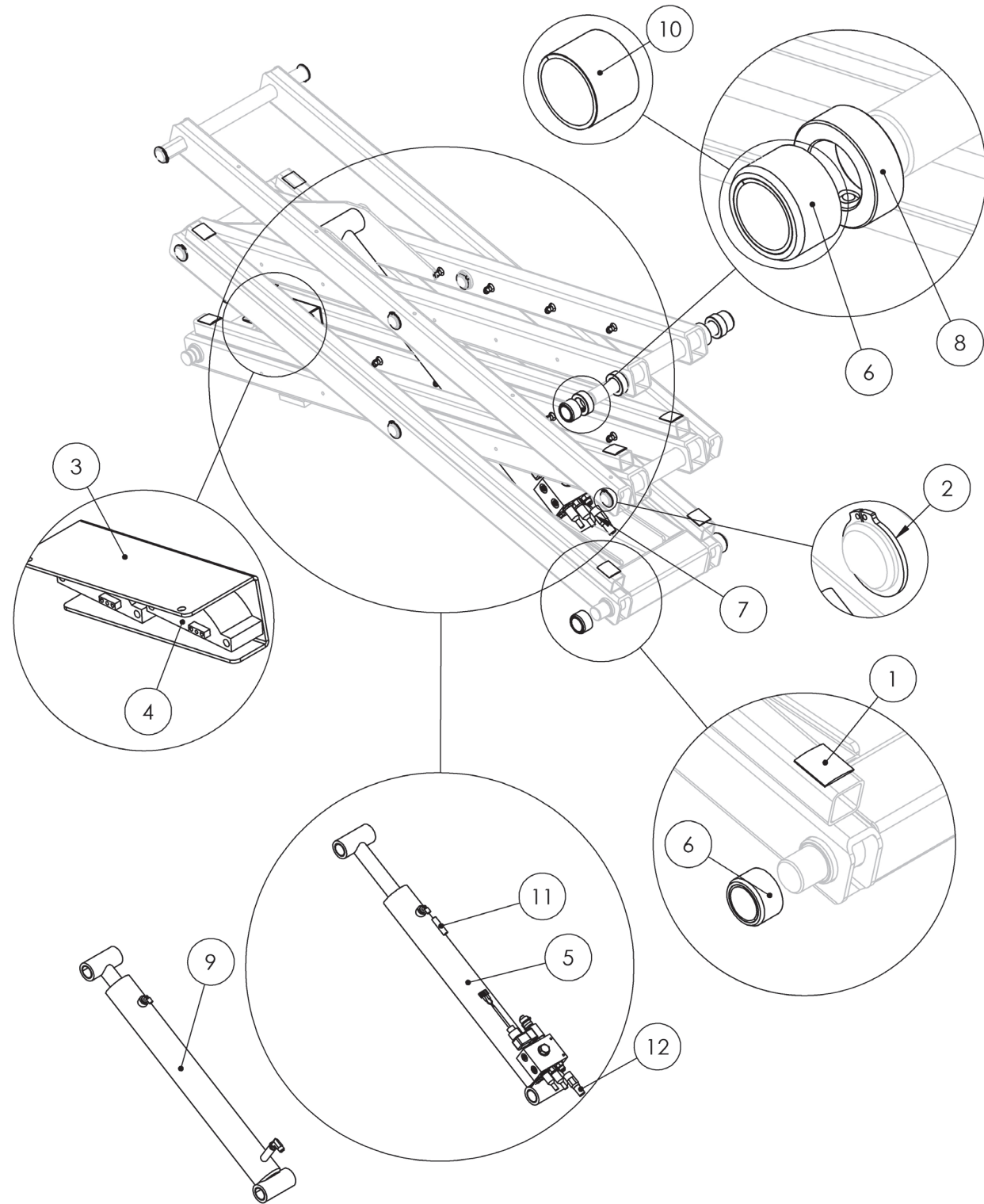

FIGURE 24: Scissors Parts - HB-830

Item #	Part Number	Part Description	Notes	Qty	Superseded By
1	129-21-009-50-K	ASM,ROLLER,1.25 W/DU		2	
2	HARD-022	1.25 RETAINING RING,EXT		14	
3	129-02-202-01	SCISSOR, ANG SENSOR MNT		1	
4	ELEC-647	SENSOR,ANGLE	Qty 1 for ANSI, 2 for CE	2	
5	129-21-005-91-K	ASM,CYL HB-830CES2	For HB-830CE	1	
6	BM-6006-1-KIT	ASM,ROLLER,1.00 W/DU		3	
7	BM-1007-EC	BUSHING,SPACER,1.38,0.25		2	
8	1021000102	SET COLLAR,1.25 ID		4	
9	129-21-232-50-K	ASM,SCISSOR CYL HB830 S2	For HB-830	1	
10	HARD-001	1.25X1.00 SLEEVE BEARING,PTFE		1	
11	HYDR-022-3	LOW PRESSURE HOSE	Quantity in inches	102	
12	HYDR-600	HOSE ASM,HB-2X		1	

3.2 | SCISSORS PARTS - HB-1230

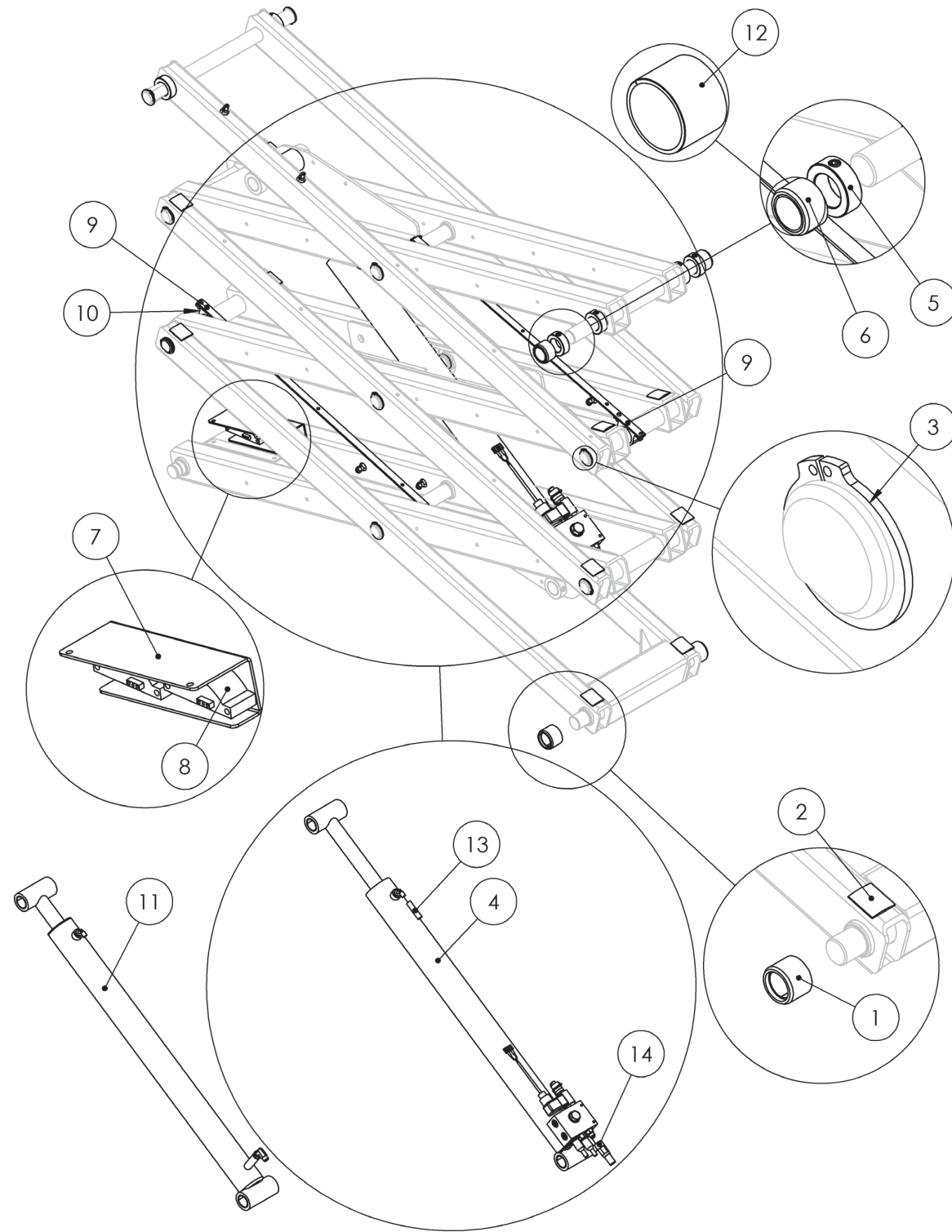

FIGURE 25: Scissors Parts - HB-1230

Item #	Part Number	Part Description	Notes	Qty	Superseded By
1	129-21-009-50-K	ASM,ROLLER,1.25 W/DU		2	
2	MISC-007-001-KIT	1 3/8 MOLDING BOND		10	
3	HARD-022	1.25 RETAINING RING,EXT		18	
4	129-21-015-51-K	ASM,CYL HB-1230-CE	For HB-1230CE	1	
5	1021000102	SET COLLAR,1.25 ID		6	
6	BM-6006-1-KIT	ASM,ROLLER,1.00 W/DU		2	
7	129-02-202-01	SCISSOR, ANG SENSOR MNT		1	
8	ELEC-647	SENSOR,ANGLE	Qty 1 for ANSI, 2 for CE	2	
9	129-02-203-11	SCISSOR,CONDUIT BRKT		2	
10	HARD-709	1.63 CLAMP		2	
11	129-21-002-90-K	ASM,SCISSOR CYL HB12-ANSI	For HB-1230	1	
12	HARD-001	1.25X1.00 SLEEVE BEARING,PTFE		1	
13	HYDR-022-3	LOW PRESSURE HOSE	Quantity in inches	132	
14	HYDR-600	HOSE ASM,HB-2X		1	

3.3 | CYLINDER SUBPARTS - ANSI
ANSI

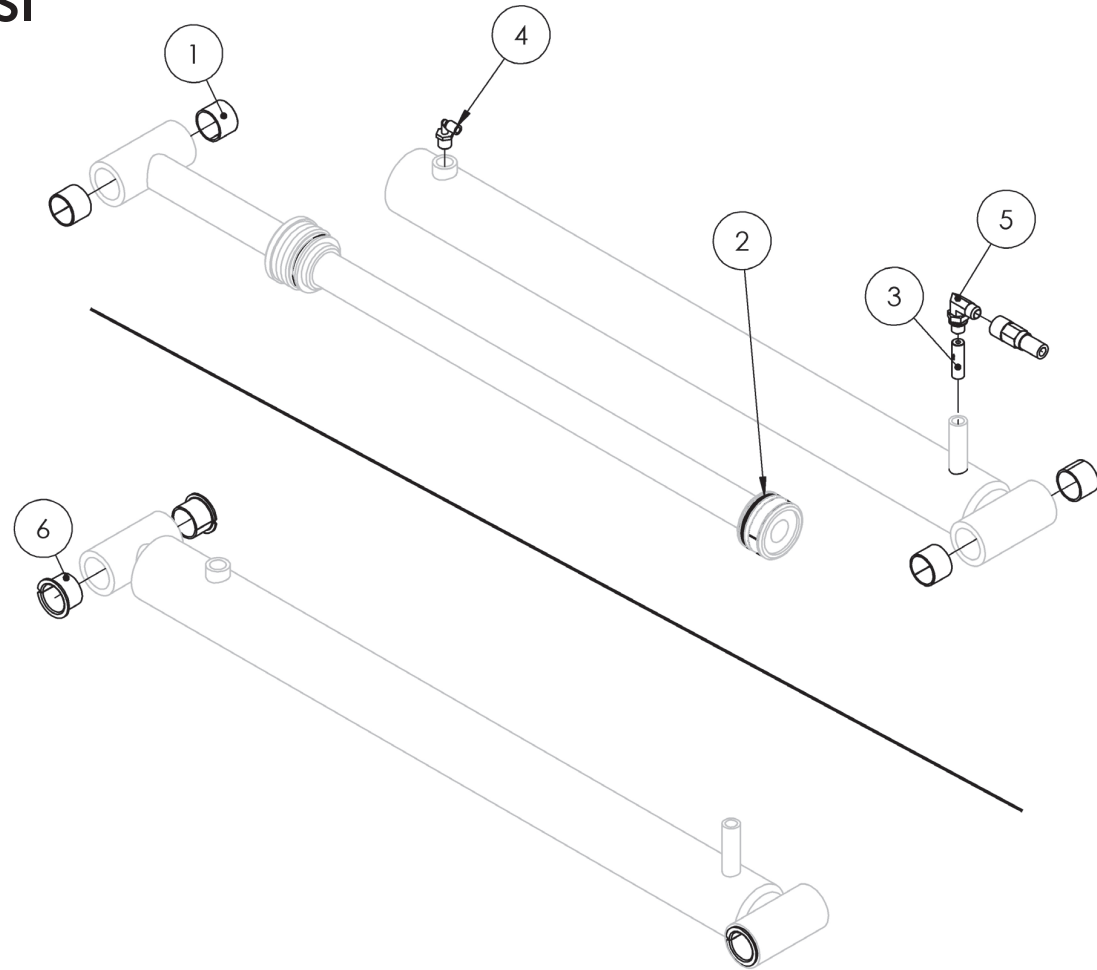

FIGURE 26: Cylinder Subparts - ANSI

Item #	Part Number	Part Description	Notes	Qty	Superseded By
1	HARD-001	1.25X1.00 SLEEVE BEARING,PTFE		4	
2	HYDR-012-SK	CYL,SEAL KIT 2.5 B,1.5 R		1	
3	HYDR-033	VELOCITY FUSE-7.0 GPM		1	
4	HYDR-019	FITTING,ELB,NPTM 3/8-1/4 PUSH		1	
5	HYDR-035	FITTING,ELB,JICM9/16-SAEORM#6		1	
6	HARD-003	1.25X1.00 FLNGE BEARING,PTFE		4	

3.4 | CYLINDER SUBPARTS - CE
CE

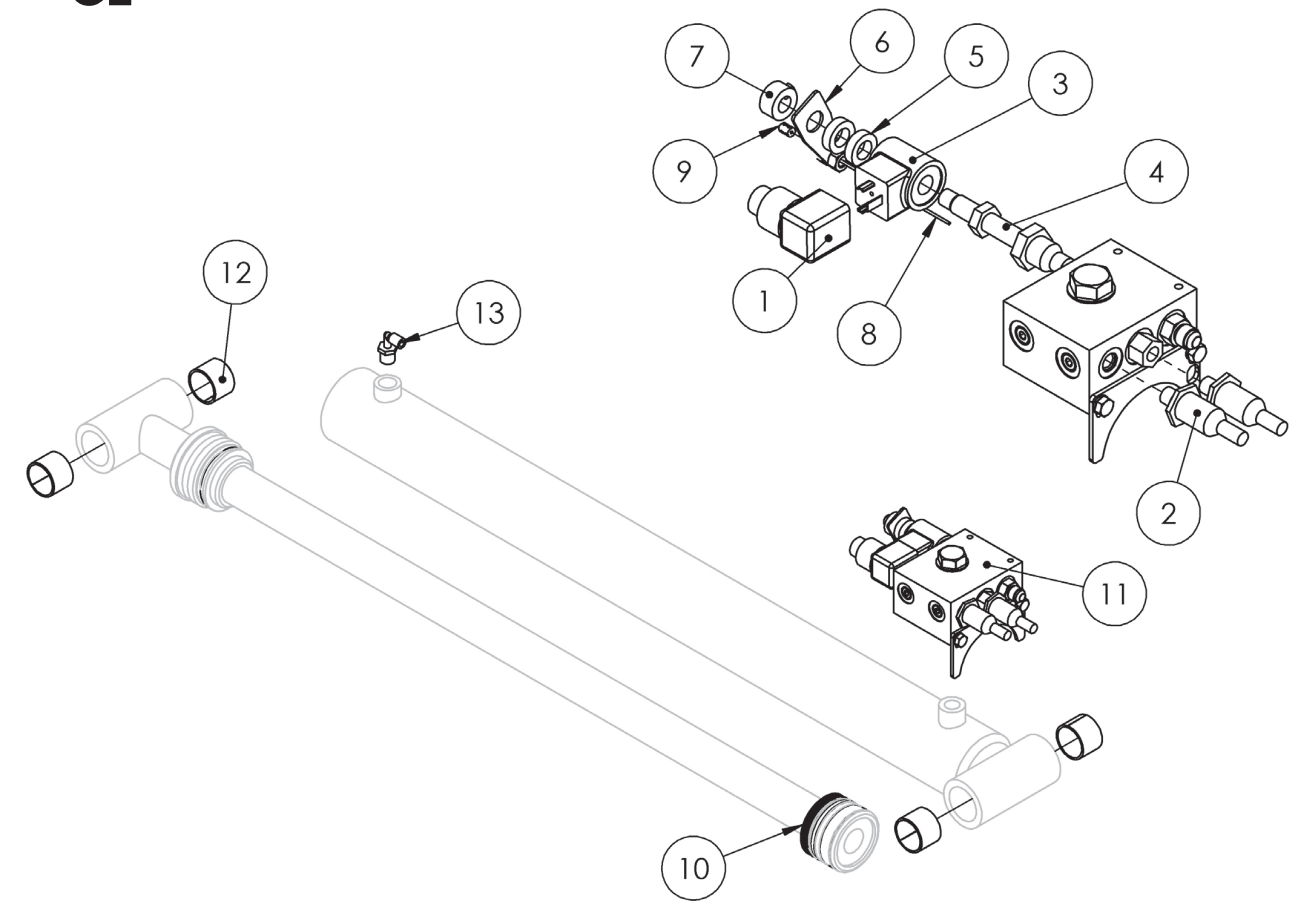
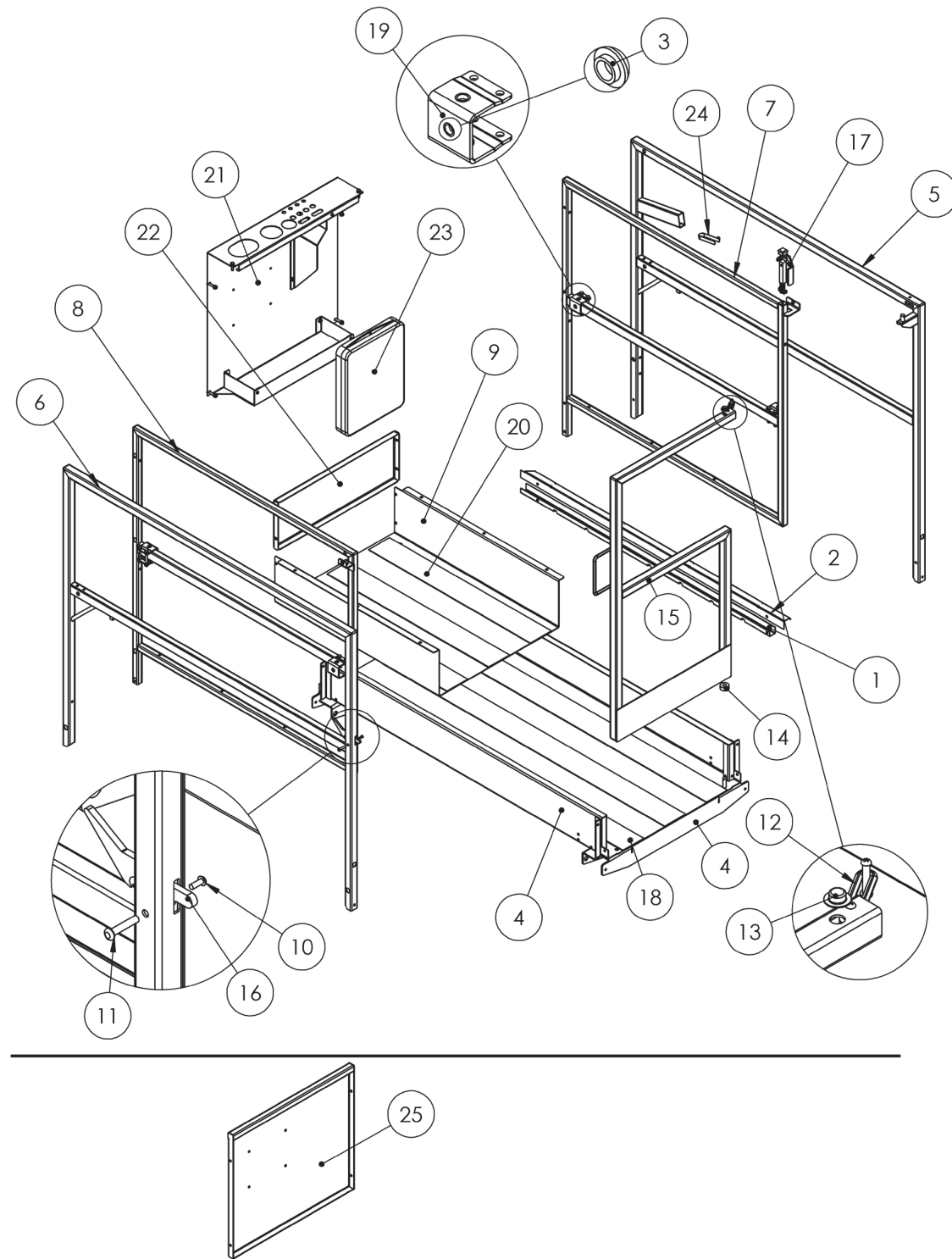

FIGURE 27: Cylinder Subparts - CE

Item #	Part Number	Part Description	Notes	Qty	Superseded By
1	HYDR-044-FL3	HIRSCHMANN CONNECTOR		1	
2	ELEC-648	SENSOR,PRESSURE		2	
3	HYDR-007-2E-4	COIL,24V,HC		1	
4	HYDR-007-2E-5	VALVE,NC,2W/2P,#8,DWN,PULL,DEL		1	
5	WHEE-605-P	0.50X0.89X0.25 SPACER		2	
6	LAS-M115	SCISSOR,PLATE E-DOWN ACT		1	
7	HARD-650	0.44X0.88X0.44 SHAFT COLLAR		1	
8	HARD-644-06	86/96 LOW FRICTION CABLE		1	
9	HARD-900	SLEEVE,CABLE STOP 0.09		1	
10	HYDR-012-SK	CYL,SEAL KIT 2.5 B,1.5 R		1	
11	129-21-013-51-K	ASM,SCISSOR CYL BLK HB-1230CE		1	
12	HARD-001	1.25X1.00 SLEEVE BEARING,PTFE		4	
13	HYDR-019	FITTING,ELB,NPTM 3/8-1/4 PUSH		1	

SECTION 4 | PLATFORM & RAILS

SECTION 4 | PLATFORM & RAILS



Item #	Part Number	Part Description	Notes	Qty	Superseded By
1	129-04-205-01	PF, CONDUIT CHANNEL LOWER		1	
2	129-04-206-01	PF, CONDUIT CHANNEL UPPER		1	
3	HARD-626	0.38X0.50X0.19 SLD WASH, NYL W	Superseded	1	HARD-626-3
3	HARD-626-3	0.38X0.50X0.19 SLD WASH, NYL B		1	
4	129-04-201-01	PF, WLD MNT		1	
5	129-03-209-01	RAIL, WC R		1	
6	129-03-203-01	RAIL, WC L		1	
7	129-03-212-01	RAIL, SO R		1	
8	129-03-214-01	RAIL, SO L		1	
9	129-03-208-01	RAIL, SO FLOOR BOLT-ON		1	
10	SCREW-1100	10-24 X 0.50 PAN HEAD SCRW		3	
11	HARD-649	0.25 X 1.25 BARREL SCRW, 10-24		3	
12	HARD-606-2	ORING, 0.25 X 5		1	
13	HARD-656-1	QUICK NUT-1/2 ROD		1	
14	143-04-007-04	SPACER, .5ID, 1.25OD, 0.5 THK		1	
15	129-03-222-01	RAIL, GATE		1	
16	1000307601	RAIL, GATE LATCH		1	
17	1002100692-KIT	ASM, RAIL SLIDE LOCK		1	
18	MISC-031-11-KIT	ANTI-SLIP TAPE, 4.00, 54.00 LENG		3	
19	LAS-M078-1-KIT	ASM, RAIL SLIDE CHNL W/WASHERS		4	
20	MISC-031-01-KIT	ANTI-SLIP TAPE, 4.00, 31.00 LENG		3	
21	129-21-321-50-K	ASM, RAIL TOOL TRAY		1	
22	129-03-211-01	RAIL, SO TOE BOARD		1	
23	HARD-603	MANUAL BOX		1	
24	HARD-067	0.38SNAP BUTTON, SINGLE END		1	
25	129-03-206-01	RAIL, SO END WLD MNT	Superseded; STANDARD YELLOW	0	129-21-321-50-K
25	129-03-206-20	RAIL, SO END WLD MNT, GRN	Superseded; GREEN	0	129-21-321-52-K

FIGURE 28: Platform & Rails

5.1 | DECALS - HB-1230 - ANSI ANSI

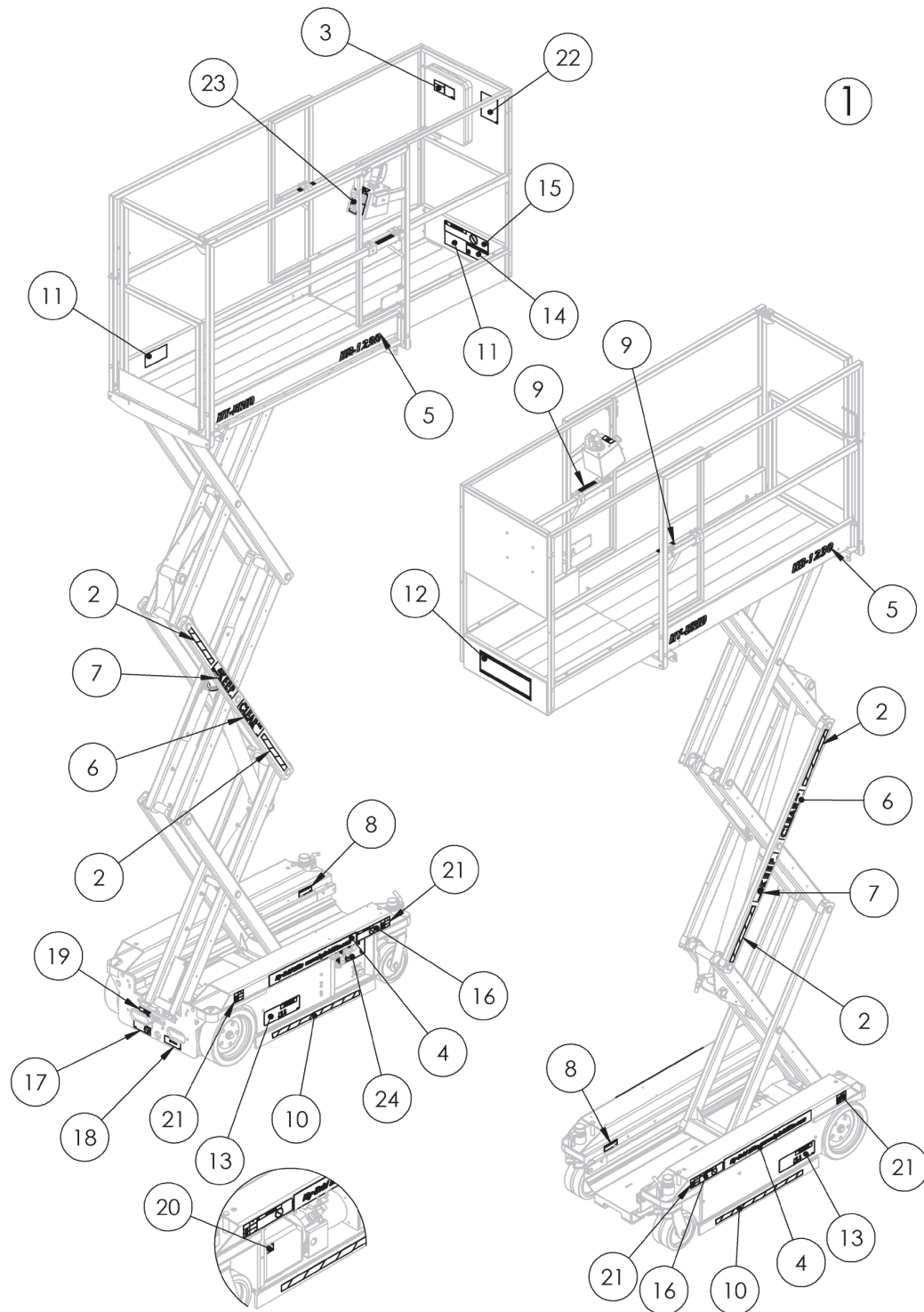

FIGURE 29: Decals - HB-1230 - ANSI

Item #	Part Number	Part Description	Notes	Qty	Superseded By
1	129-21-212-50-K	DECALS,HB-1230 S2 ANSI		1	
2	DE717-62	DECAL,SAFETY STRIPE (12.00)		4	
3	DE600E-10	DECAL,MANUAL BOX		1	
4	DE652	DECAL,WEBSITE	Superseded; D08-20001-D08-20043	0	DE822
4	DE822	DECAL,WEBSITE	D08-20001-D08-20043	2	
5	DE603-6	MODEL# DECAL-HB-1230		2	
6	DE708	DECAL,CLEAR		2	
7	DE707	DECAL,KEEP		2	
8	DE600E-14	DECAL,MAINT LOCK		2	
9	DE746	DECAL,LANYARD ATTACHMENT		2	
10	DE717-61	DECAL,SAFETY STRIPE (24.00)		2	
11	DE712	DECAL,CAPACITY,550#,2P,I,W/SO		2	
12	DE821	DECAL,LOGO HY-BRID		1	
13	DE709	DECAL, LWR		2	
14	DE706	DECAL,UPR HB		1	
15	DE719	DECAL,CASTERLOCK		1	
16	DE721	DECAL,CASTERLOCK		2	
17	DE747	DECAL,BRAKE RELEASE/NO TOW		1	
18	DE751	DECAL,E-DOWN CABLE		1	
19	DE753	DECAL,CHARGER CORD		1	
20	DE679	DECAL,HYDR FLUID		1	
21	DE748	DECAL,WHEEL LOAD HB-1230 S2		4	
22	DE755	DECAL,ERROR ALARMS		1	
23	DE702	DECAL,CTL UPR ANSI		1	
24	DE704	DECAL,CTL LWR ANSI ZTR-MID		1	
25	DE601	DECAL,LOGO HY-BRID	Superseded	1	DE821

5.2 | DECALS - HB-1230 - CE
CE

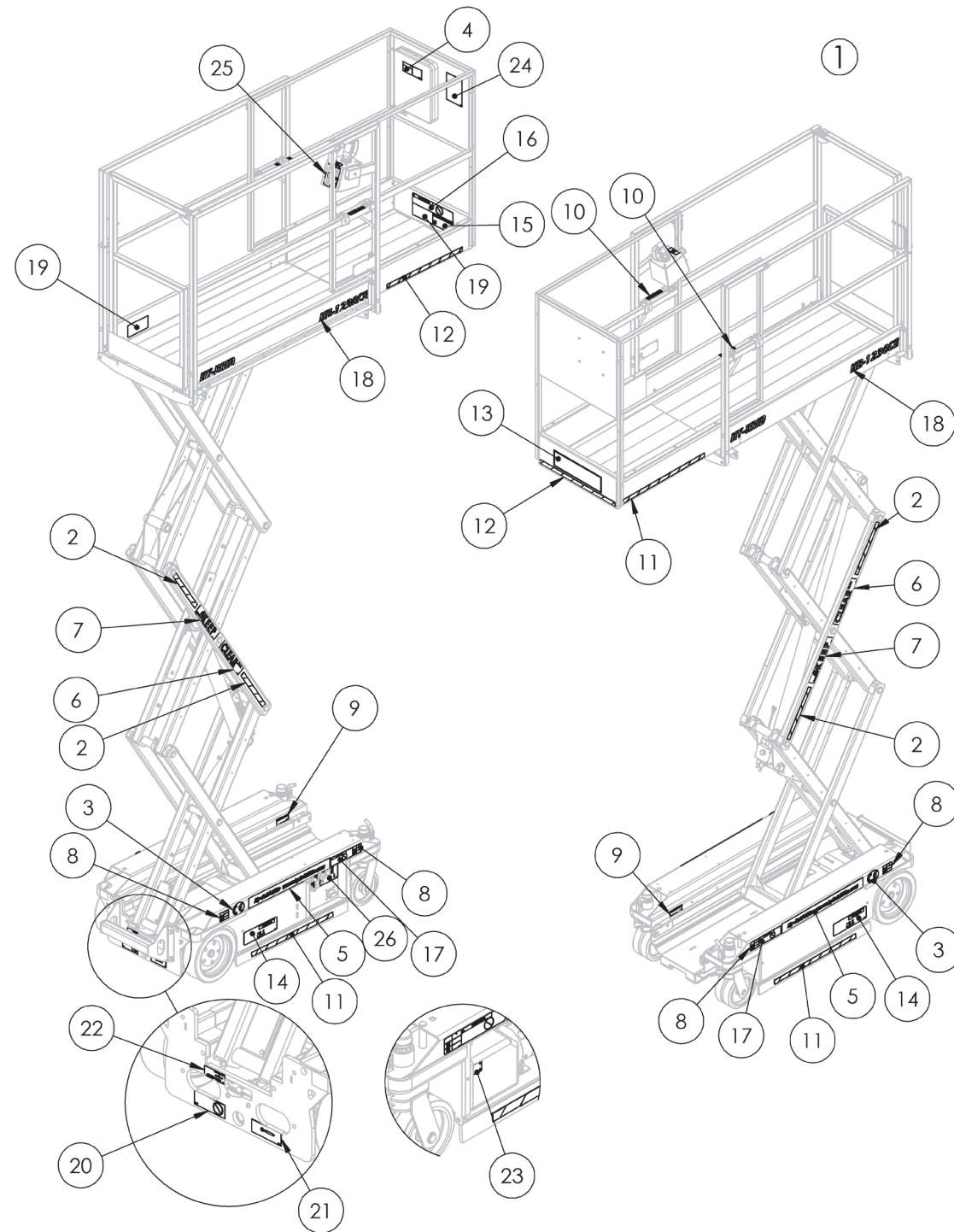

FIGURE 30: Decals - HB-1230 - CE

Item #	Part Number	Part Description	Notes	Qty	Superseded By
1	129-21-212-51-K	DECALS,HB-1230 CE		1	
2	DE717-62	DECAL,SAFETY STRIPE (12.00)		4	
3	DE718	DECAL,CE		2	
4	DE600E-10	DECAL,MANUAL BOX		1	
5	DE652	DECAL,WEBSITE	Superseded;	0	DE822
5	DE822	DECAL,WEBSITE		2	
6	DE708	DECAL,CLEAR		2	
7	DE707	DECAL,KEEP		2	
8	DE749	DECAL,WHEEL LOAD HB-1230CE S2		4	
9	DE600E-14	DECAL,MAINT LOCK		2	
10	DE746	DECAL,LANYARD ATTACHMENT		2	
11	DE717-61	DECAL,SAFETY STRIPE (24.00)		3	
12	DE717-63	DECAL,SAFETY STRIPE (22.25)		2	
13	DE821	DECAL,LOGO HY-BRID		1	
14	DE709	DECAL, LWR		2	
15	DE706	DECAL,UPR HB		1	
16	DE719	DECAL,CASTERLOCK		1	
17	DE721	DECAL,CASTERLOCK		2	
18	DE603-16	MODEL# DECAL-HB-1230CE		2	
19	DE750	DECAL,CAPACITY,550#,1P,I,W/SO		2	
20	DE747	DECAL,BRAKE RELEASE/NO TOW		1	
21	DE751	DECAL,E-DOWN CABLE		1	
22	DE752	DECAL,CHARGER CORD (EU)		1	
23	DE679	DECAL,HYDR FLUID		1	
24	DE756	DECAL,ERROR ALARMS CE		1	
25	DE703	DECAL,CTL UPR CE		1	
26	DE705	DECAL,CTL LWR CE ZTR-MID		1	
27	DE601	DECAL,LOGO HY-BRID	Superseded;	1	DE821

5.3 | DECALS - HB-830 - ANSI
ANSI

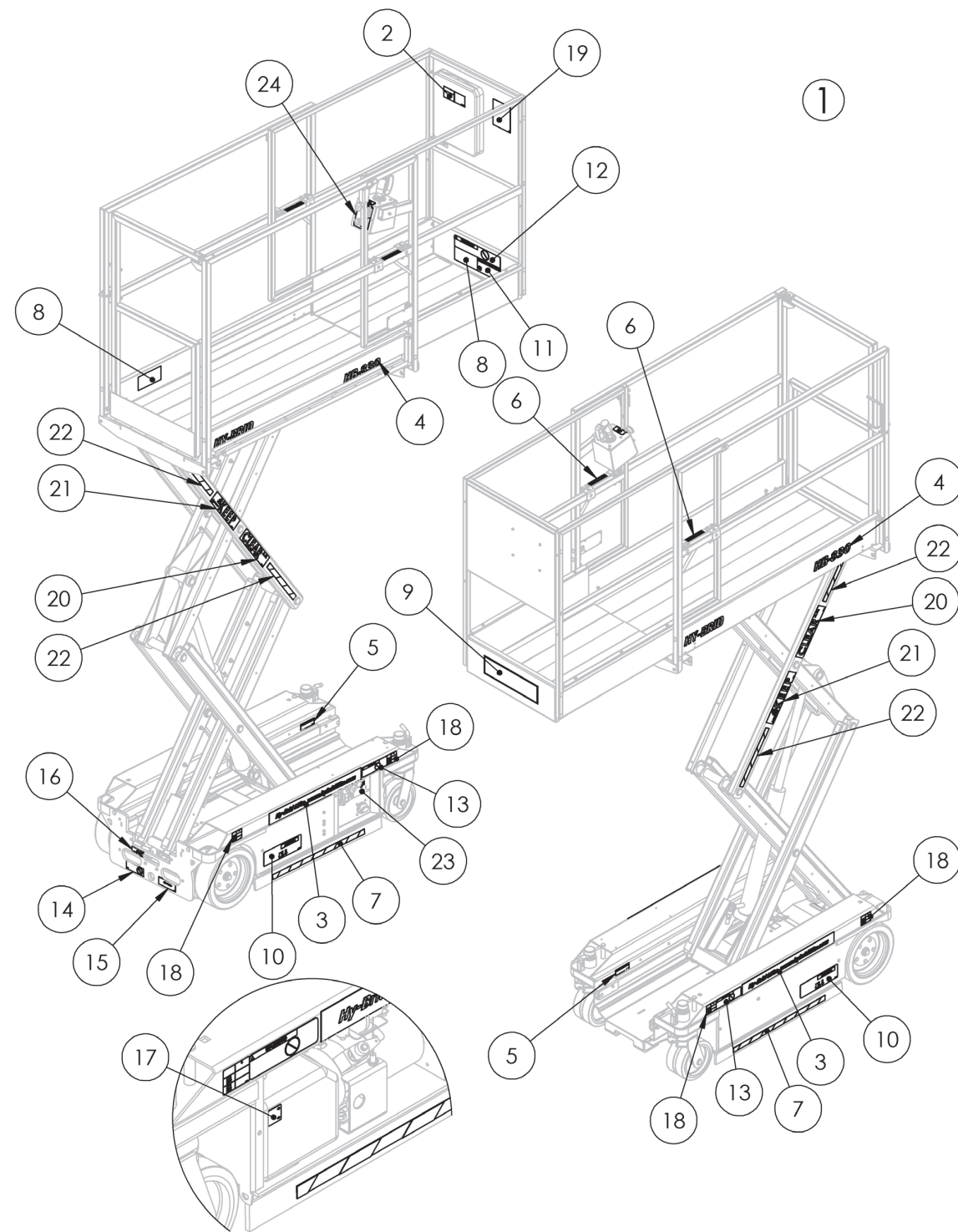

FIGURE 31: Decals - HB-830 - ANSI

Item #	Part Number	Part Description	Notes	Qty	Superseded By
1	129-21-231-50-K	DECALS,HB-830 S2 ANSI		1	
2	DE600E-10	DECAL,MANUAL BOX		1	
3	DE652	DECAL,WEBSITE	Suoperseded;	2	DE822
3	DE822	DECAL,WEBSITE		2	
4	DE603-2	DECAL,MODEL #HB-830		2	
5	DE600E-14	DECAL,MAINT LOCK		2	
6	DE746	DECAL,LANYARD ATTACHMENT		2	
7	DE717-61	DECAL,SAFETY STRIPE (24.00)		2	
8	DE712	DECAL,CAPACITY,550#,2P,I,W/SO		2	
9	DE821	DECAL,LOGO HY-BRID		1	
10	DE709	DECAL, LWR		2	
11	DE706	DECAL,UPR HB		1	
12	DE719	DECAL,CASTERLOCK		1	
13	DE721	DECAL,CASTERLOCK		2	
14	DE747	DECAL,BRAKE RELEASE/NO TOW		1	
15	DE751	DECAL,E-DOWN CABLE		1	
16	DE753	DECAL,CHARGER CORD		1	
17	DE679	DECAL,HYDR FLUID		1	
18	DE757	DECAL,WHEEL LOAD HB-830 S2		4	
19	DE755	DECAL,ERROR ALARMS		1	
20	DE708	DECAL,CLEAR		2	
21	DE707	DECAL,KEEP		2	
22	DE717-62	DECAL,SAFETY STRIPE (12.00)		4	
23	DE705	DECAL,CTL LWR CE ZTR-MID		1	
24	DE702	DECAL,CTL UPR ANSI		1	
25	DE601	DECAL,LOGO HY-BRID	Superseded;	1	DE821

5.4 | DECALS - HB-830 - CE
CE

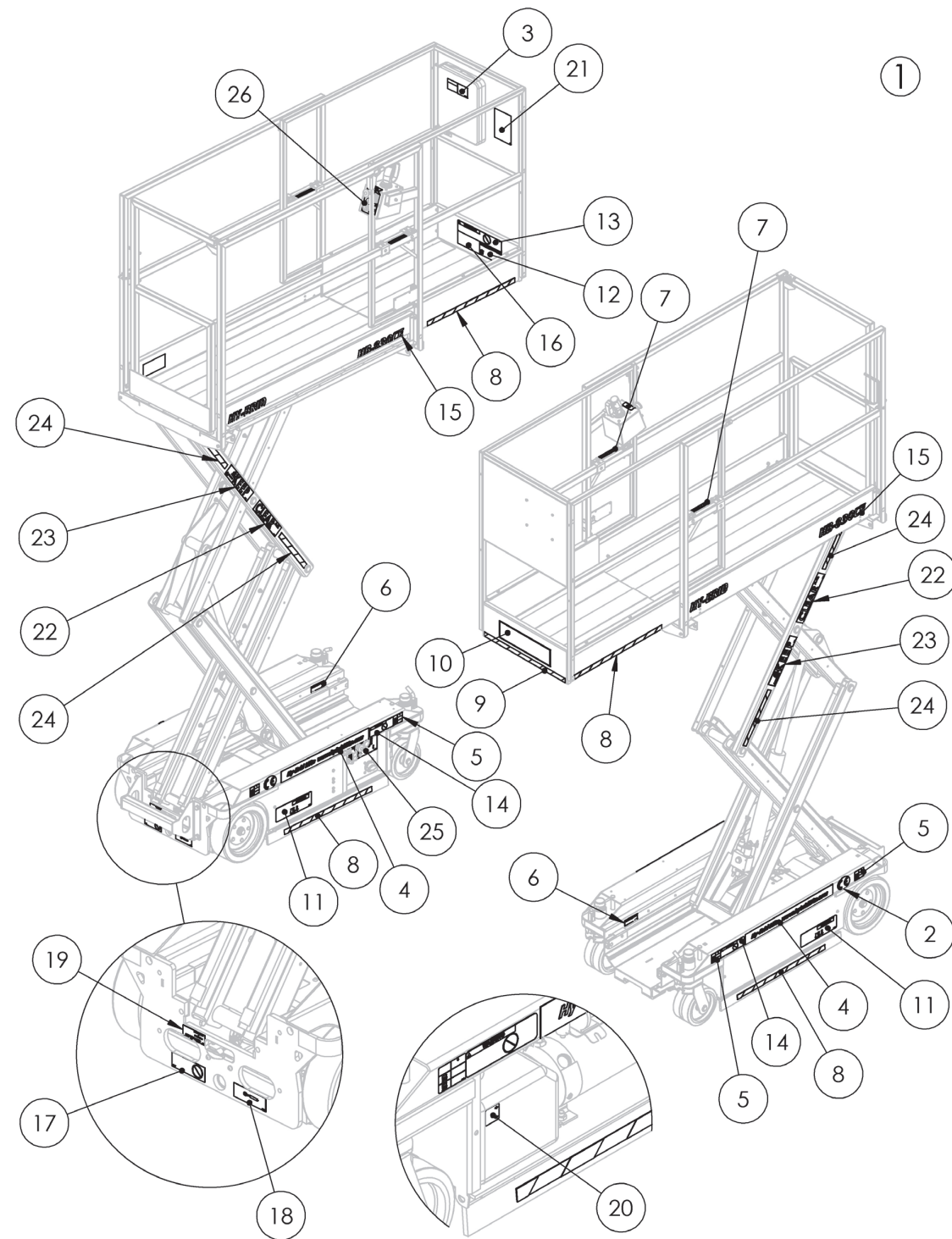
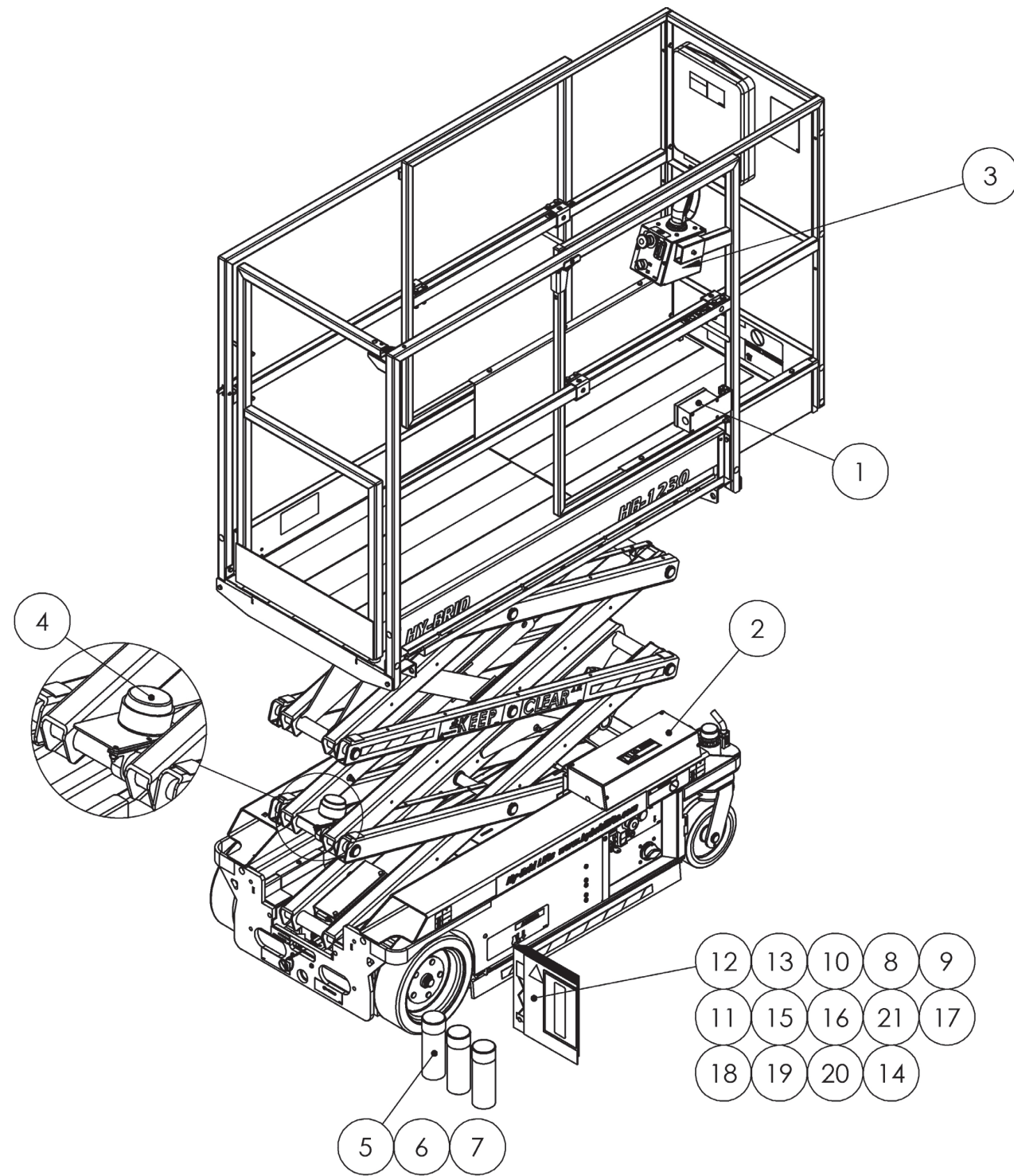

FIGURE 32: Decals - HB-830 - CE

Item #	Part Number	Part Description	Notes	Qty	Superseded By
1	129-21-231-51-K	DECALS,HB-830CE S2		1	
2	DE718	DECAL,CE		2	
3	DE600E-10	DECAL,MANUAL BOX		1	
4	DE652	DECAL,WEBSITE	Superseded	2	DE822
4	DE822	DECAL,WEBSITE		2	
5	DE758	DECAL,WHEEL LOAD HB-830CE S2		4	
6	DE600E-14	DECAL,MAINT LOCK		2	
7	DE746	DECAL,LANYARD ATTACHMENT		2	
8	DE717-61	DECAL,SAFETY STRIPE (24.00)		4	
9	DE717-63	DECAL,SAFETY STRIPE (22.25)		1	
10	DE821	DECAL,LOGO HY-BRID		1	
11	DE709	DECAL, LWR		2	
12	DE706	DECAL,UPR HB		1	
13	DE719	DECAL,CASTERLOCK		1	
14	DE721	DECAL,CASTERLOCK		2	
15	DE603-17	MODEL# DECAL-HB-830CE		2	
16	DE750	DECAL,CAPACITY,550#,1P,I,W/SO		2	
17	DE747	DECAL,BRAKE RELEASE/NO TOW		1	
18	DE751	DECAL,E-DOWN CABLE		1	
19	DE752	DECAL,CHARGER CORD (EU)		1	
20	DE679	DECAL,HYDR FLUID		1	
21	DE756	DECAL,ERROR ALARMS CE		1	
22	DE708	DECAL,CLEAR		2	
23	DE707	DECAL,KEEP		2	
24	DE717-62	DECAL,SAFETY STRIPE (12.00)		4	
25	DE704	DECAL,CTL LWR ANSI ZTR-MID		1	
26	DE703	DECAL,CTL UPR CE		1	
27	DE601	DECAL,LOGO HY-BRID	Superseded:	1	DE821



Item #	Part Number	Part Description	Notes	Qty	Superseded By
1	129-21-219-50-K	ASM,PTP HB1230S2		1	
2	129-21-238-50-K	ASM,INVERTER OPT		1	
3	129-21-236-50-K	ASM,UPR CTL CONNECTOR ALT		1	
4	129-21-235-50-K	BEACON,FLASHING(AMBER) HBMD S2		1	
5	MISC-624	PAINT,WHITE TOUCH-UP SPRAY		1	
6	MISC-625	PAINT,YELLOW TOUCH-UP SPRAY		1	
7	MISC-627	PAINT,GREEN TOUCH-UP SPRAY		1	
8	SUPO-657	MANUAL,OP HB-830/1230 S2		1	
9	SUPO-657F	MANUAL,OP HB-830/1230 S2,FR		1	
10	SUPO-658	MANUAL,MAINT HB-830/1230 S2		1	
11	SUPO-658F	MANUAL,MAINT HB-830/1230 S2,FR		1	
12	MISC-601	MANUAL,RESPONSIBILITIES A92.6		1	
13	MISC-600	MANUAL,AERIAL PF		1	
14	SUPO-660	DOCUMENT,CE DECL HB-1230CE S2		1	
15	SUPO-653	MANUAL,MAINT HB-830/1230CE S2		1	
16	SUPO-652	MANUAL,OP HB-830/1230CE S2		1	
17	SUPO-674	DOC,HB-1230 UNIQUE FEATURES		1	
18	SUPO-674FRC	DOC,HB-1230 UNIQUE FEATURES,FR	FRENCH LANGUAGE	1	
19	SUPO-674SPA	DOC,HB-1230 UNIQUE FEATURES,SP	SPANISH LANGUAGE	1	
20	SUPO-686	MANUAL,PARTS HB-830/1230S2		1	
21	SUPO-667	DOCUMENT,CSA DECL HB-1230 S2		1	
22	HS-129-20-201-50	HYDR SCH,HBMD S2/3	HB-830 & HB-1230 HYDRAULIC SCHEMATIC	1	
23	HS-129-20-201-51	HYDR SCH,HBMDCE S2/3	HB-830CE & HB-1230CE HYDRAULIC SCHEMATIC	1	

FIGURE 33: Options & Miscellaneous

HY-BRID LIFTS™

BY CUSTOM EQUIPMENT LLC

Self-Propelled Aerial Work Platform
Parts Manual
HB-830/HB-830CE/HB-1230/HB-1230CE

© 2018 Custom Equipment, LLC
2647 Highway 175
Richfield, WI 53076
U.S.A.
Tel.: +1-262-644-1300
Fax: +1-262-644-1320
www.hybridlifts.com
Service@Customequipmentlifts.com

"Hy-Brid Lifts" is a trademark of Custom Equipment, LLC
These machines comply with specified ANSI, CSA and EN280
requirements

Revision Date: April 2018

Printed In The USA